

PRODUCT DATA

Dimensions, technical data
and specifications

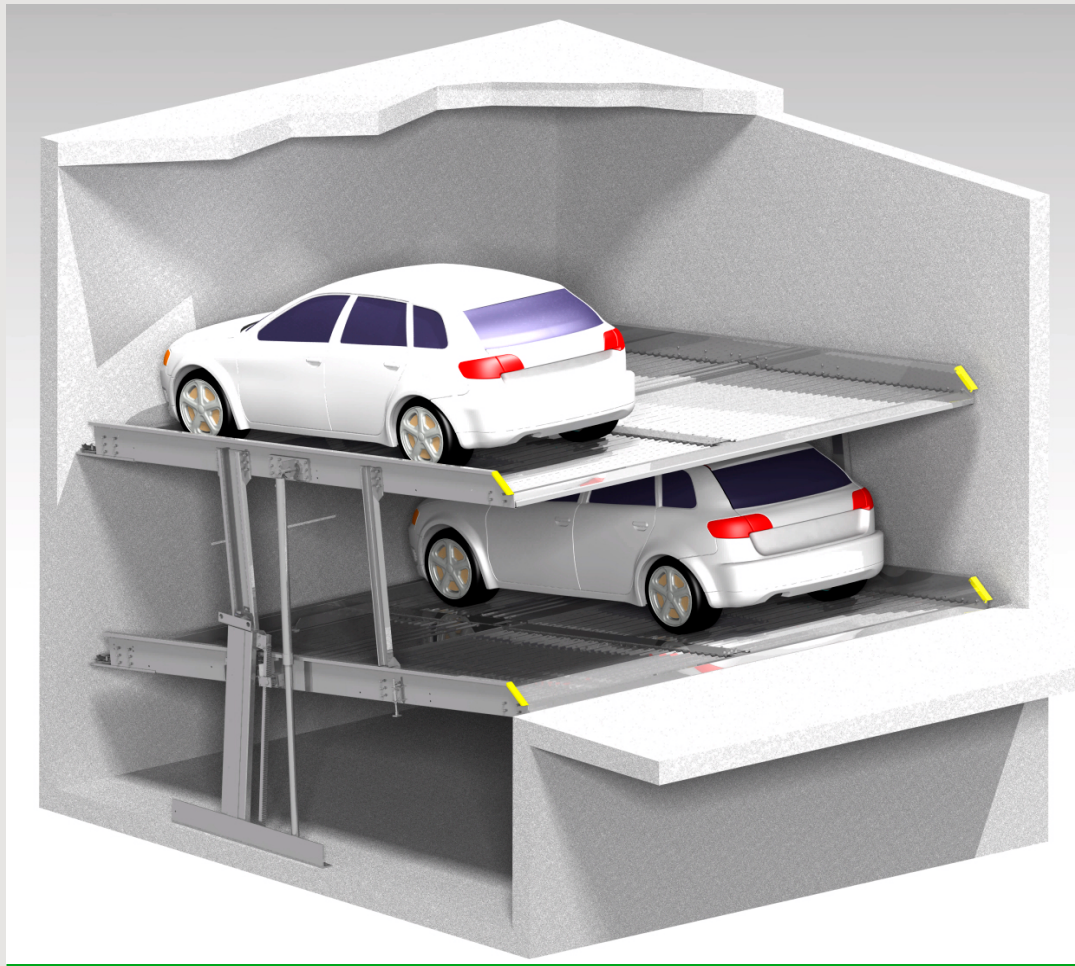

G24





E-mail sales@levelpark-rs.com
 Internet www.levelpark-rs.com

G24 (Retrofit) Stack Parker

Dimensions

All space requirements are minimum finished dimensions. Tolerances for space requirements ³ °

Dimensions in cm

Type	H	D1	D2
G24-165*	295	165	170
G24-165	305	165	170
G24-170	310	170	175
G24-175	315	175	180
G24-180	320	180	185
G24-185	325	185	190
G24-190	330	190	195
G24-195	335	195	200

*only for standard passenger cars - limousine

Dimensions in cm

Type	H	H Up	H Down
G24-165*	295	150	150
G24-165	305	150	150
G24-170	310	150	155
G24-175	315	150	160
G24-180	320	150	165
G24-185	325	150	170
G24-190	330	150	175
G24-195	335	150	180

*only for standard passenger cars - limousine

Standard passenger car (L)

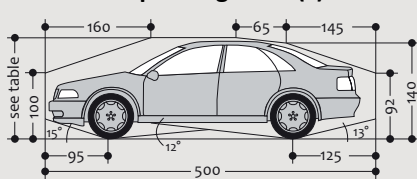

Standard station wagon (K)

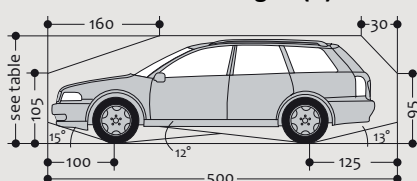

Standard passenger cars are vehicles without any sports options such as spoilers, low-profile tires, etc.

Parking possibilities

	Standard G24
Width in cm	190 ³
Weight in kg	max.2000
Wheel load in kg	max.500



The systems provided are consistent with DIN EN 14010, the VDMA 15423 spec. and the EC Machinery Directive 2006/42/EC.



Platforms accessible tilted.



Max. load per parking space in kg.

Specification

- SP (single platform) = 2 vehicles
- DP (double platform) = 4 vehicles
- Independent parking
- Both levels easily accessible
- Car heights 150 cm - 180 cm
- Car length 500 cm - 520 cm
- Usable platform width up to 270 cm for SP, and up to 520 cm for DP
- Standard load capacity 2000kg per parking space

Garage without door

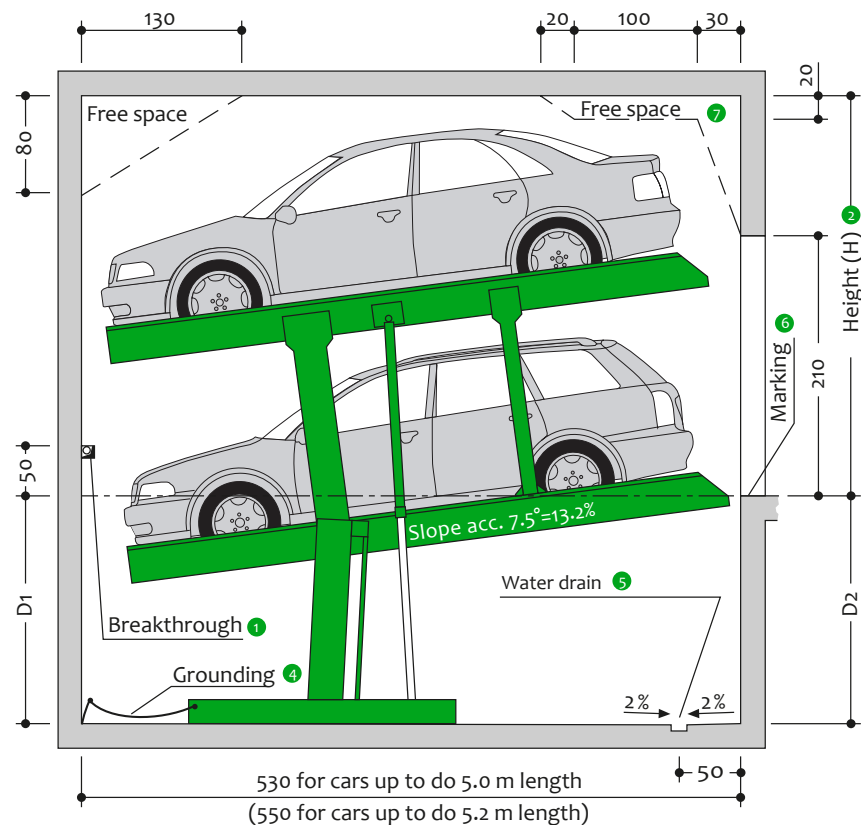

Notes

- 1 For dividing walls: cutting through 10 x 10 cm.
- 2 If a higher ceiling height is available, higher cars can be parked.
- 3 Max. vehicle width (measured through the rearview mirror, overall dimensions) for a platform with a main opening of 230 cm. For more comfortable use, we recommend a platform width of 250 to 270 cm (SP) or 500 cm (DP)
- 4 Grounding of the system to be connected to the central grounding on-site (to be provided by the customer).
- 5 Slope with drainage channel and sump.
- 6 In compliance with DIN EN 14010, 10 cm wide yellow-black markings compliant to ISO 3864 must be applied by the customer to the edge of the pit in the entry area to mark the danger zone (see "Load plan", page 4).
- 7 The free space does not apply to the caravan on the upper platform.

Width dimensions for garage without door

Dividing walls

Single platform (SP)

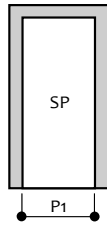

Usable platform width	P1
220	250
230	260
240	270
250	280
260	290
270	300

Double platform (DP)

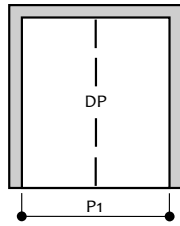

Usable platform width	P1
450	480
460	490
470	500
480	510
490	520
500	530
510	540
520	550

Single and double platform (SP + DP) – Example

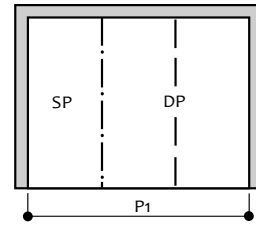

Usable platform width	P1
220+450	730
230+460	750
240+470	770
250+480	790
250+490	810
270+500	830
270+510	840
270+520	850

Tramline according to local regulations

Page 1
Sections, dimensions, car data

Page 2
Width dimensions, without door

Page 3
Dimensions with garage door

Page 4
Load plan

Page 5
Installation data electrical installation

Page 6
Technical hint

Page 7
On-site services

Page 8
Description SP + DP

Columns in pit

Single platform (SP)

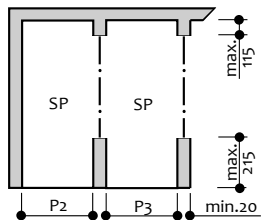

Usable platform width	P2	P3
220	245	240
230	255	250
240	265	260
250	275	270
260	285	280
270	295	290

Double platform (DP)

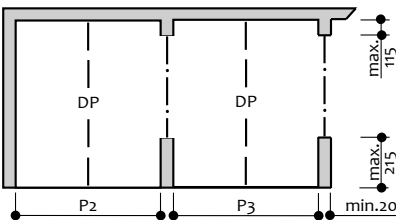

Usable platform width	P2	P3
450	475	465
460	485	475
470	495	485
480	505	495
490	515	505
500	525	515
510	535	525
520	545	535

Single and double platform (SP + DP) – Example

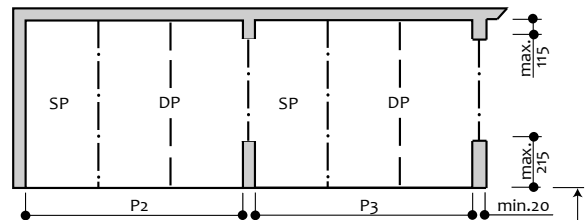

Usable platform width	P2	P3
220+450	725	715
230+460	745	735
240+470	765	755
250+480	785	775
250+490	805	795
270+500	825	815
270+510	835	825
270+520	845	835

Tramline according to local regulations

Columns outside pit

Single platform (SP)

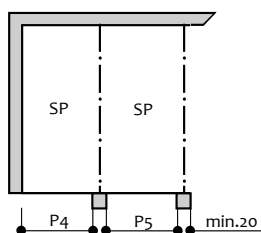

Usable platform width	P4	P5
220	240	230
230	250	240
240	260	250
250	270	260
260	280	270
270	290	280

Double platform (DP)

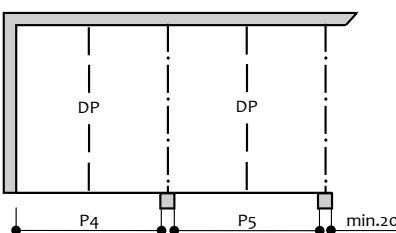

Usable platform width	P4	P5
450	470	460
460	480	470
470	490	480
480	500	490
490	510	500
500	520	510
510	530	520
520	540	530

Single and double platform (SP + DP) – Example

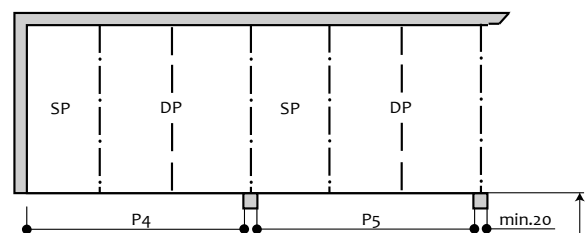

Usable platform width	P4	P5
220+450	720	710
230+460	740	730
240+470	760	750
250+480	780	770
250+490	800	790
270+500	820	810
270+510	830	820
270+520	840	830

Tramline according to local regulations



HINT: End parking spaces are generally more difficult to park. Narrower platform widths can cause problems during use (depending on the type of car, access and individual driving behaviour). We recommend our wider platforms for end parking spaces.

Garage with door in front of the parking system

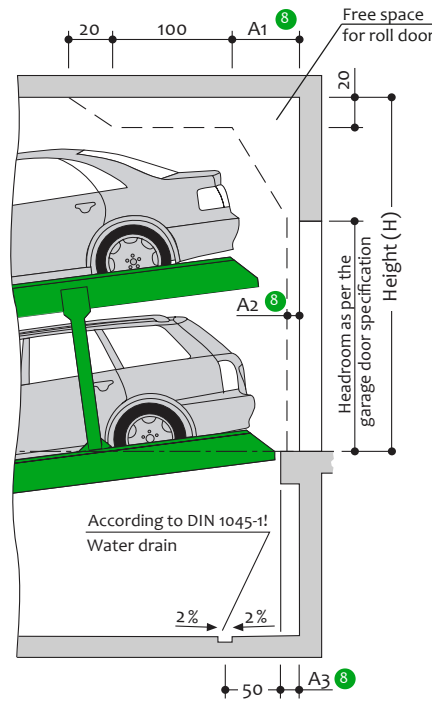

⑧ Dimensions A1, A2 and A3 must be coordinated with the door supplier.

Widths for garage with door in front of car parking system

Single platform (SP)

Double platform (DP)

Usable platform width	Door entrance width LO	L	S
220	220	15	30
230	237 ⁵	12 ⁵	25
240	250	12 ⁵	25
250	250	15	30
260	260	15	30
270	270	15	30

Usable platform width	Door entrance width LO	L	S
450	450	15	30
460	460	15	30
470	475	12 ⁵	25
480	475	17 ⁵	35
490	500	12 ⁵	25
500	500	15	30
510	510	15	30
520	520	15	30

Tramline according to local regulations

⑧ All-round door dimensions require coordination between door supplier and producer of parking system.

Page 1
Sections, dimensions, car data

Page 2
Width dimensions, without door

Page 3
Dimensions with garage door

Page 4
Load plan

Page 5
Installation data electrical installation

Page 6
Technical hint

Page 7
On-site services

Page 8
Description SP + DP

Access incline

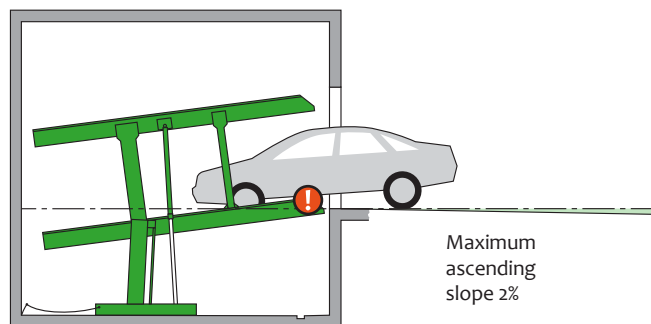
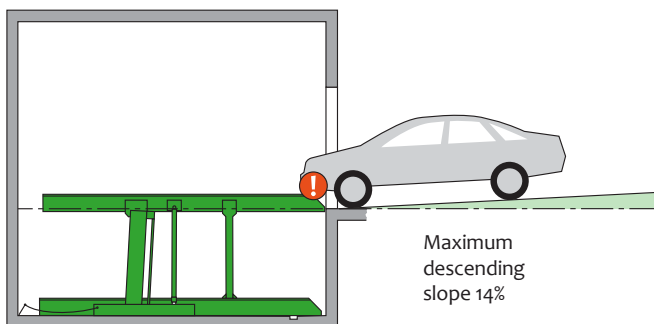

The illustrated maximum approach angles must not be exceeded. Incorrect approach angles will cause serious maneuvering and positioning problems on the parking system for which the producer accepts no responsibility.

Load plan

Forces in kN

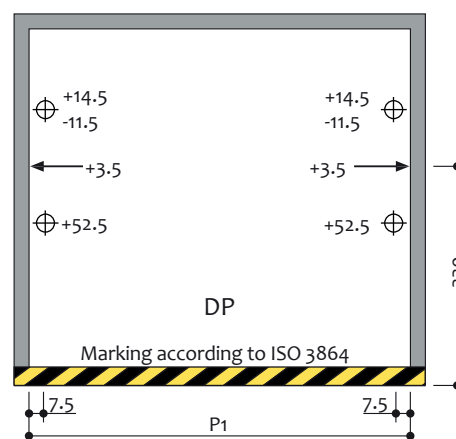
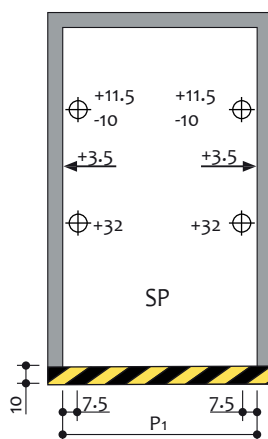
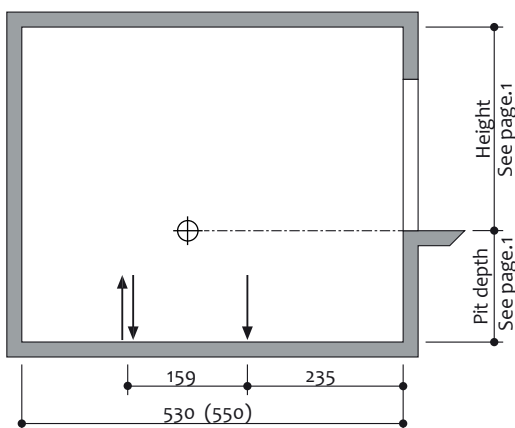

Page 1
Sections, dimensions, car data

Page 2
Width dimensions, without door

Page 3
Dimensions with garage door

Page 4
Load plan

Page 5
Installation data electrical installation

Page 6
Technical hint

Page 7
On-site services

Page 8
Description SP + DP



HINT: Units are dowelled to the floor. Drilling depth: approx. 15 cm.

The floor plate and walls must be from concrete (quality min. C20/25).

End parking spaces are generally more difficult to park. Narrower platform widths can cause problems during use (depending on the type of car, access and individual driving behaviour). We recommend our wider platforms for end parking spaces.

Installation data

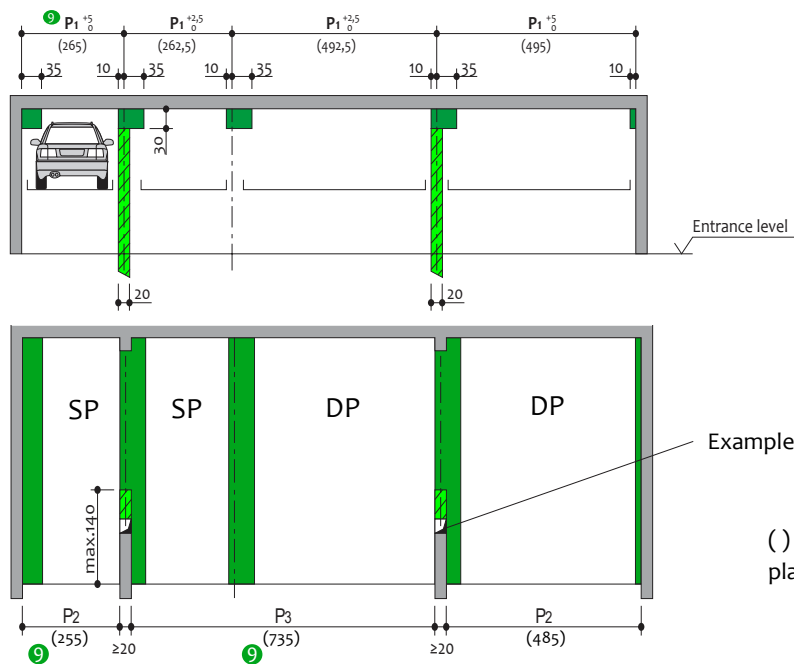

- Free space for vertical pipelines, ventilation ducts
- Clearances for longitudinal guidance

⑨ Dimensions P1, P2 and P3 see pages 3,4 and 5.

Example of ducting or vertical pipelines

() = The measurements in brackets are an example for platforms with a main opening of SP230/DP460 cm.



HINT: Free spaces apply only to forward parked cars with driver exit on the left side!

Electrical installation

Installation diagram

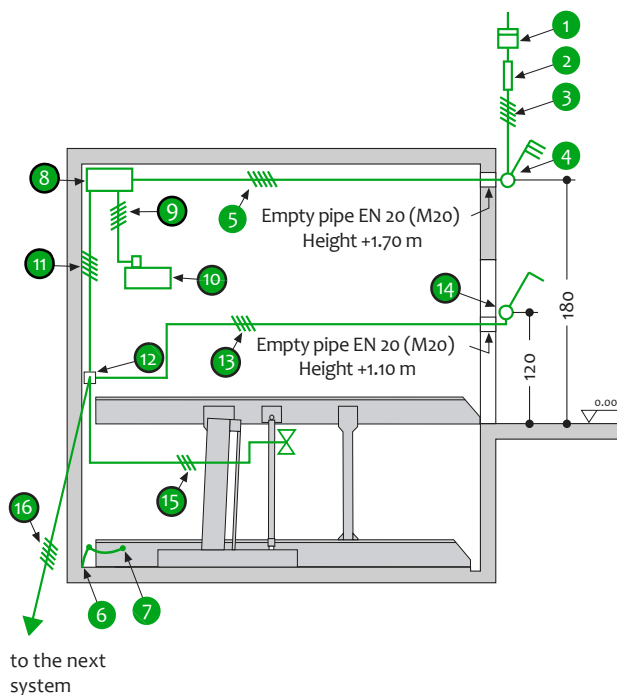

Electrical data to be performed by the customer

No.	Qty.	Description	Position	Frequency
1	1	Power meter	in the supply line	
2	1	Pre-fuse: 3x safety fuse 16 A (slow-blow) or Circuit breaker 3x16 A (trip characteristic K or C)	in the supply line	1 per 3,0 kW unit
3	1	Supply line 5 x 2,5mm ² (3 PH + N + PE) with marked wire and protective conductor	to main switch	1 per unit
4	1	Lockable main switch	defined by the project	1 per unit
5	1	Supply line 5 x 2,5mm ² (3 PH + N + PE) with marked wire and protective conductor	from main switch to main cabinet	1 per unit
6	1	Potential equalization from foundation grounding connection system acc. to DIN EN 60204		1 per system
7	every 10 m	Foundation earth connector	corner pit floor	

Electrical data included in delivery of producer

No.	Description
8	Main cabinet
9	Supply cable 5 x 2,5 mm ² 400VAC, with marked wire and protective conductor
10	Hydraulic unit 3,0 kW, 3 phase 400 V/50 Hz
11	Control line 5 x 1,5 mm ² 24VDC, with marked wire and protective conductor
12	Distribution unit
13	Control line 5 x 1,5 mm ² 24VDC, with marked wire and protective conductor
14	Key switch, 2 way momentary with emergency stop
15	Control line 3 x 0,75 mm ² 24VDC, with marked wire and protective conductor
16	Connection cable to the next system 5 x 1,5 mm ² with marked wire and protective conductor

Page 1

Sections, dimensions, car data

Page 2

Width dimensions, without door

Page 3

Dimensions with garage door

Page 4

Load plan

Page 5

Installation data electrical installation

Page 6

Technical hint

Page 7

On-site services

Page 8

Description SP + DP

Technical hint

Application area

By default, the system is not suitable for short-term parkers (changing users). If necessary, please contact producer of parking system.

Power pack

Installed on vibration metal mounted, low-noise hydraulic power units. Nevertheless, we recommend separating the garage from the house.

Available documents

- Wall recess plans
- Maintenance offer/contract
- Declaration of conformity

Corrosion protection

According to the supplementary sheet of corrosion protection.

Balustrade / Barriers

When the allowable fall is exceeded, balustrades are attached to the equipment. If the traffic lanes are directly next to or behind the installations, barriers according to DIN EN 294 (DIN EN ISO 13857) are required on site. This also applies during the construction phase.

Environmental conditions

Ambient conditions for the range of our parking systems: Temperature range -10 to +40° C. Relative humidity 50% with a maximum outside temperature of +40° C. If lifting or lowering durations are mentioned, these refer to an ambient temperature of +10° C and an arrangement of the system immediately next to the hydraulic unit. At lower temperatures or longer hydraulic lines, these durations increase.

Soundproofing

According to DIN 4109 (sound insulation in building construction), para. 4, note 4, parking systems fall into the field of technical installations (garage systems).

Normal sound insulation (Special agreement) DIN 4109, Supplement 4, Note for planning and execution, proposals for increased sound insulation. In paragraph 4.1, Table 4, the values for the permissible sound pressure levels in rooms requiring protection are specified for noise from building services. According to line 2, the maximum sound pressure level in living rooms and bedrooms must not exceed 30 dB (A). Noise from the user is not subject to the requirements (see Table 4, DIN 4109).

The following measures are required to maintain this value:

- Soundproofing package according to offer/order
- Sound insulation of the building in min. $R'w = 57$ dB (performance on site)

Increased sound insulation

DIN 4109, paragraph 4, noise protection of technical equipment and installations.

Agreement: Maximum sound pressure level in living rooms and bedrooms 25 dB (A). User noises are not subject to the requirements (see Table 4, DIN 4109).

The following measures are required to maintain this value:

- Soundproofing package according to offer/order
- Sound insulation of the building in min. $R'w = 62$ dB (performance on site)



HINT: The user's noises are essentially noises that can be individually influenced by the user of our parking systems. These include for example driving on the platform, slamming vehicle doors, engine noise and brake.

Page 1
Sections,
dimensions,
car data

Page 2
Width
dimensions,
without
door

Page 3
Dimensions
with garage
door

Page 4
Load plan

Page 5
Installation
data
electrical
installation

Page 6
Technical
hint

Page 7
On-site
services

Page 8
Description
SP + DP

To be performed by the customer

Balustrade / Barriers

Possibly required barriers according to DIN 294 for securing the parking pits in traffic lanes directly in front of, beside or behind the facilities. This also applies during the construction phase. Railings on the systems, if required, are included optional!

Numbering of parking spaces

Continuous numbering of parking spaces.

Building services

Lighting, ventilation, fire extinguishing and fire alarm systems.

Drainage

In the front of the pit, we recommend to plan a water collecting gutter and to connect it to a ground drain or a pit (50 x 50 x 20 cm) In the canal, a lateral slope is possible, but not in the remaining area of the pit (the gradient in the longitudinal direction is due to the dimensions). In the interest of environmental protection, a painting of the bottom of the pit should be made. Oil or gas separators are recommended for connection to the sewer system.

Marking

In accordance with DIN EN 14 010, a warning mark must be affixed to the access zone to identify this danger zone in accordance with ISO 3864. The design shall be in accordance with EN 92/58/EEC for installations with a pit (platforms inside the pit) 10 cm from the edge of the pit.

Wall openings

Possibly required wall openings according to sectional drawings on page 1.

Electrical supply to the control box/Foundation earth connector

The supply line to the main switch and the control line to the unit must be made by the customer during installation. The functionality can be checked by our technicians on site together with the electrician. If this is not possible during assembly for reasons attributable to the customer, an electrician must be commissioned by the customer. The steel construction is to be provided on site with foundation earthing connection (grounding distance max 10 m) and potential equalization according to DIN EN 60204.

Control panel

Empty conduits and cut-outs for the control element (with hinged doors, a prior consultation with producer of parking system is necessary).

Control panel on plaster

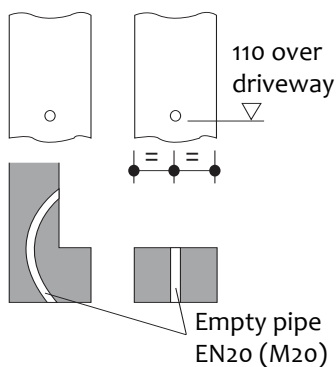

Control panel under plaster

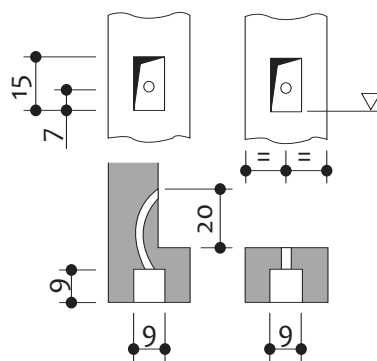

The following costs must be supported by the customer, if they are not included in the offer:

- Complete wiring of the individual components according to the wiring diagram
- Cost of final technical approval by an authorized expert
- Main switch
- Control line from the main switch to the control cabinet
- Railing
- Floor marking

Page 1

Sections, dimensions, car data

Page 2

Width dimensions, without door

Page 3

Dimensions with garage door

Page 4

Load plan

Page 5

Installation data electrical installation

Page 6

Technical hint

Page 7

On-site services

Page 8

Description SP + DP

Description single platform (SP) and double platform (DP)**General description**

- The parking system provides independent parking spaces of 2 cars (SP), 2x2 cars (DP) on top of each other
- Dimensions according to the underlying pit, width and height dimensions
- The pitches are driven horizontally and have a gradient of $\pm 1^\circ$ for proper drainage of the platforms
- Access to the lower platform is at a slope of approximately 7.5° .
- Passenger car positioning on each parking space by means of a positioning aid mounted on the right-hand side (to be set in accordance with the operating instructions)
- Operation via a control element with automatic reset by means of a key that closes the same way
- Fixing the control element usually in front of the support or on the way revealing the outside
- Operating instructions at every operating point
- For garages with an entrance door, special dimensions must be respected

The parking system consists of:

- 2 Pillars with foundation rails (fixed to the floor)
- 2 Sliding pieces (with sliding guides attached to the pillars)
- 2 Platforms
- 1 mechanical synchronization system (for the synchronous operation of the hydraulic cylinders during lifting and lowering)
- 2 Hydraulic cylinders
- 2 rigid supports (connection of the platforms)
- 1 automatic hydraulic breakage protection (prevents involuntary lowering when driving on)
- Dowels, screws, fasteners, bolts etc.

Platform consisting of:

- Platform profiles
- Adjustable positioning aids
- Beveled bumpers
- Lateral beams
- Bearing center [DP only]
- Brackets
- Screws, nuts, spacer tubes, etc.

Hydraulics consisting of:

- Hydraulic cylinder
- Magnetic valve
- Line break security
- Hydraulic lines
- Fittings
- High pressure hoses
- Mounting material

Electrics consisting of:

- Control element (EMERGENCY STOP, lock, 1 key with the same key per parking space)
- Sub-distribution
- Control cabinet

Hydraulic unit consisting of:

- Hydraulic unit (low noise, mounted on bracket)
- Hydraulic oil tank
- Oil filling
- Internal gear pump
- Pump support
- Coupling
- Three-phase motor (3.0 kW/5.2 kW/400 V, 50 Hz)
- Pressure gauge
- Pressure relief valve
- Hydraulic hoses (to dampen noise transmission on hydraulic pipes)

We reserve the right to change these specifications without notice!

Producer reserves the right in the course of technical progress to use newer or different technologies systems, processes, procedures or standards than those originally offered, if the customer does not incur any disadvantage.

Page 1

Sections, dimensions, car data

Page 2

Width dimensions, without door

Page 3

Dimensions with garage door

Page 4

Load plan

Page 5

Installation data electrical installation

Page 6

Technical hint

Page 7

On-site services

Page 8

Description SP + DP