

PRODUCT DATA

Dimensions, technical data
and specifications

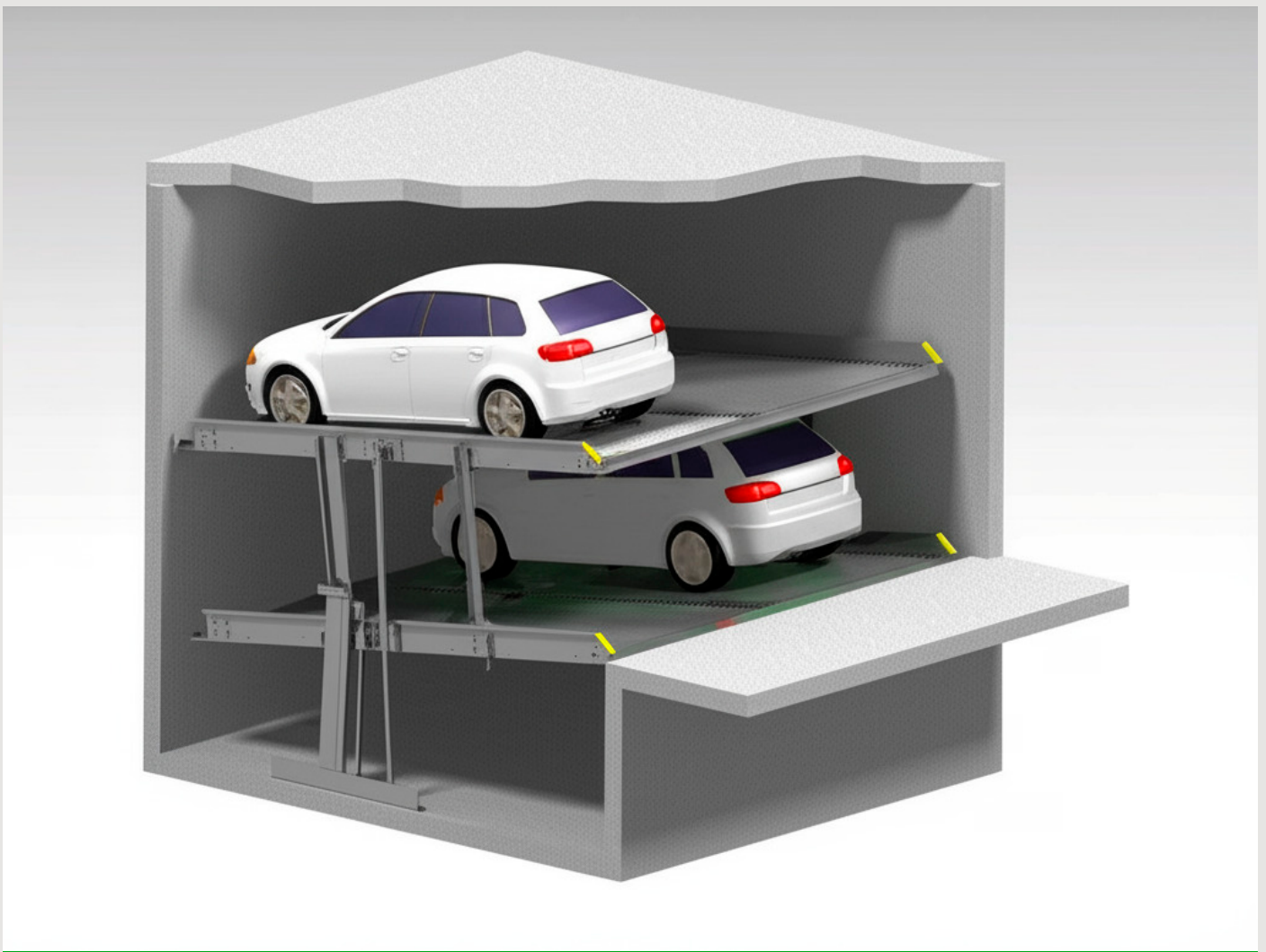

N7.1





E-mail sales@levelpark-rs.com
 Internet www.levelpark-rs.com

N7.1(N7.1K) Stack Parker

Dimensions

All space requirements are minimum finished dimensions. Tolerances for space requirements ⁺³ ₀ ①

Standard passenger car (L)

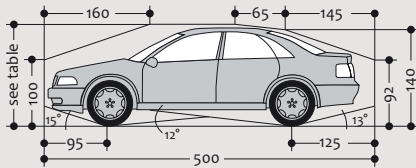

Standard station wagon (K)

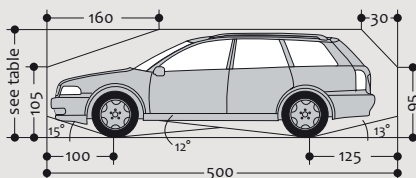

Standard passenger cars are vehicles without any sports options such as spoilers, low-profile tires, etc.

Parking possibilities

	Standard N7.1	Reinforced N7.1K
Width in cm	190 ②	190 ②
Weight in kg	max.2000	2600
Wheel load in kg	max.500	650

Height dimensions

All pit and height variants can be found on page 2

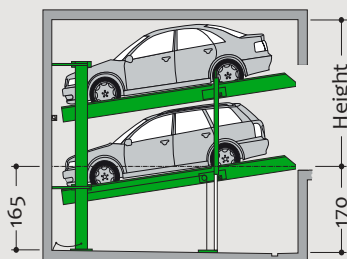

Smallest version

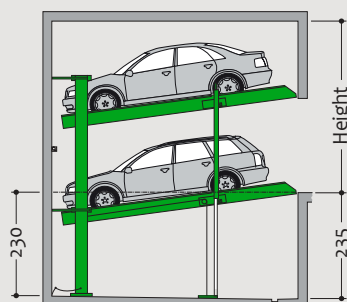

Largest version



The systems provided are consistent with DIN EN 14010, the VDMA 15423 spec. and the EC Machinery Directive 2006/42/EC.



Platforms accessible tilted.



Max. load per parking space in kg.



Upweighting over 2000 kg possible with surcharge.



Parking space load can be subsequently upweighted.

Specification

- SP (single platform) = 2 vehicles
- DP (double platform) = 4 vehicles
- Independent parking
- Horizontal access to all parking levels
- Car heights 150 cm - 215 cm
- Car length 500 cm - 520 cm
- N7.1 (Standard) : Load capacity = 2000 kg per parking place, usable platform width up to 270 cm for SP and up to 520 cm for DP
- N7.1K (Reinforced) : Load capacity = 2600 kg or max. 3000 kg per parking place. Usable platform width up to 270 cm for SP and up to 540 cm for DP

Garage without door

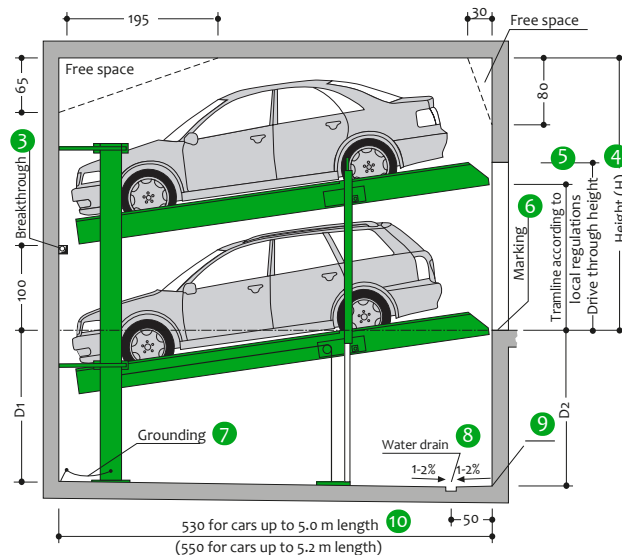

Notes

- ① To comply with the minimum finished dimensions, the tolerances according to VOB, Part C (DIN 18330 and 18331) and DIN 18202 must also be considered.
- ② Car width for platform width 230 cm. For the greatest possible ease-of-use, we recommend
 - N7.1 - platform widths of 250 to 270 cm (SP) or 520 cm (DP)
 - N7.1K - platform widths 250 to 270 cm (SP) or 520 to 540 cm (DP)
- ③ For dividing walls: cutting through 10 x 10 cm.
- ④ If a higher ceiling height is available, higher cars can be parked.
- ⑤ Must be at least as high as the greatest car height + 5 cm.
- ⑥ In compliance with DIN EN 14010, 10 cm wide yellow-black markings compliant to ISO 3864 must be applied by the customer to the edge of the pit in the entry area to mark the danger zone (see "Load plan", page 7).
- ⑦ Grounding of the system to be connected to the central grounding on-site (to be provided by the customer).
- ⑧ Slope with drainage channel and sump.
- ⑨ At the transition section between the pit floor and walls, no hollow mouldings/coves are possible. If hollow mouldings/coves are required, the systems must be designed smaller or the pits accordingly wider.
- ⑩ For cars up to a length of 5.30 m, we recommend a pit length of 5.50 m.

Page 1
Sections, dimensions, car data

Page 2
Height dimensions

Page 3
Function, Width dimensions divid.walls

Page 4
Width dimensions, columns in pit

Page 5
Width dimensions, columns outside pit

Page 6
Front door termination, Width dimensions

Page 7
Approach Load plan

Page 8
Installation data / electrical installation

Page 9
Technical hint

Page 10
On-site services

Page 11
Description SP + DP

Overview of stack parker variants and building heights

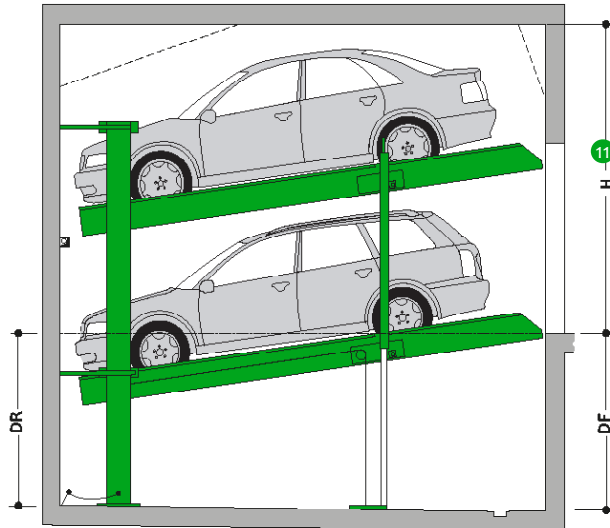

H: Ceiling height
DF: Pit depth, front
DR: Pit depth, rear

11 If the ceiling is higher, correspondingly higher vehicles can be parked on the top.

Type	DR	DF	Vehicle height, lower	Vehicle height, passenger car, upper																H - Ceiling height		
				150	155	160	165	170	175	180	185	190	195	200	205	210	215	Vehicle height, station wagon, upper				
				150	155	160	165	170	175	180	185	190	195	200	205	210	215	220				
N7.1-165	165	170	150	290	295	300	305	310	315	320	325	330	335	340	345	350	355	360	365	370	375	
N7.1-170	170	175	155	295	300	305	310	315	320	325	330	335	340	345	350	355	360	365	370	375	380	
N7.1-175	175	180	160	300	305	310	315	320	325	330	335	340	345	350	355	360	365	370	375	380	385	
N7.1-180	180	185	165	305	310	315	320	325	330	335	340	345	350	355	360	365	370	375	380	385	390	
N7.1-185	185	190	170	310	315	320	325	330	335	340	345	350	355	360	365	370	375	380	385	390	395	
N7.1-190	190	195	175	315	320	325	330	335	340	345	350	355	360	365	370	375	380	385	390	395	400	
N7.1-195	195	200	180	320	325	330	335	340	345	350	355	360	365	370	375	380	385	390	395	400	405	
N7.1-200	200	205	185	325	330	335	340	345	350	355	360	365	370	375	380	385	390	395	400	405	410	
N7.1-205	205	210	190	330	335	340	345	350	355	360	365	370	375	380	385	390	395	400	405	410	415	
N7.1-210	210	215	195	335	340	345	350	355	360	365	370	375	380	385	390	400	400	405	410	415	420	
N7.1-215	215	220	200	340	345	350	355	360	365	370	375	380	485	390	395	405	405	410	415	420	425	
N7.1-220	220	225	205	345	350	355	360	365	370	375	380	385	390	395	400	410	410	415	420	425	430	
N7.1-225	225	230	210	350	355	360	365	370	375	380	385	390	395	400	405	415	420	425	430	435	440	
N7.1-230	230	235	215	355	360	365	370	375	380	385	390	395	400	405	410	415	420	425	430	435	440	

Example configuration



Example: Vehicle height lower 160 cm, vehicle height upper 160 cm for passenger car and 150 cm for station wagon.
Type: N7.1 - 175
Ceiling height: 310 cm

Type	DR	DF	Vehicle height, lower	Vehicle height, passenger car, upper																H		
				150	155	160	165	170	175	180	185	190	195	200	205	210	215	Vehicle height, station wagon, upper				
				150	155	160	165	170	175	180	185	190	195	200	205	210	215	220				
N7.1-165	165	170	150	290	295	300	305	310	315	320	325	330	335	340	345	350	355	360	365	370	375	
N7.1-170	170	175	155	295	300	305	310	315	320	325	330	335	340	345	350	355	360	365	370	375	380	
N7.1-175	175	180	160	300	305	310	315	320	325	330	335	340	345	350	355	360	365	370	375	380	385	
N7.1-180	180	185	165	305	310	315	320	325	330	335	340	345	350	355	360	365	370	375	380	385	390	

Function

System raised

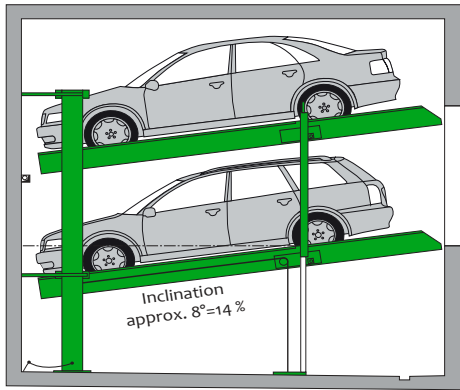

System lowered

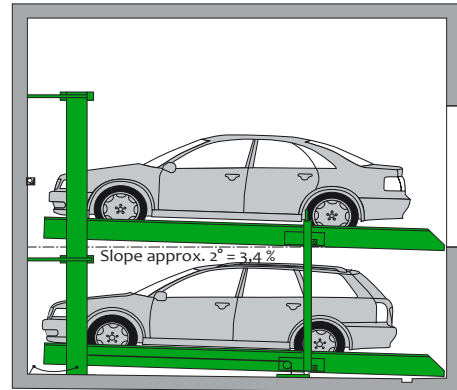

Page 1
Sections,
dimensions,
car data

Page 2
Height
dimensions

Page 3
Function,
Width
dimensions
div.d walls

Page 4
Width
dimensions,
columns
in pit

Page 5
Width
dimensions,
columns
outside pit

Page 6
Front door
termination,
Width
dimensions

Page 7
Approach
Load plan

Page 8
Installation
data /
electrical
installation

Page 9
Technical
hint

Page 10
On-site
services

Page 11
Description
SP + DP

Width dimensions for garage without door (underground car park)

Dividing walls

Single platform (SP)

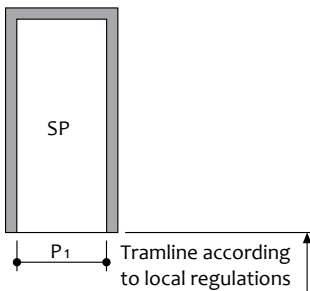

Usable platform width	P1
220	250
230	260
240	270
250	280
260	290
270	300

Double platform (DP)

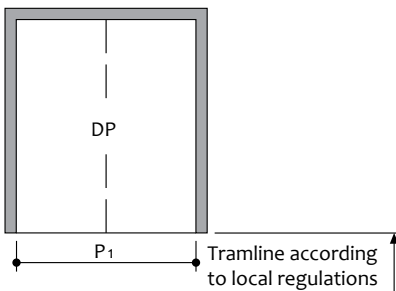

Usable platform width	P1
450	480
460	490
470	500
480	510
490	520
500	530
510	540
520	550
530*	560
540*	570

*only N7.1K

Single and double platform (SP + DP) – Example

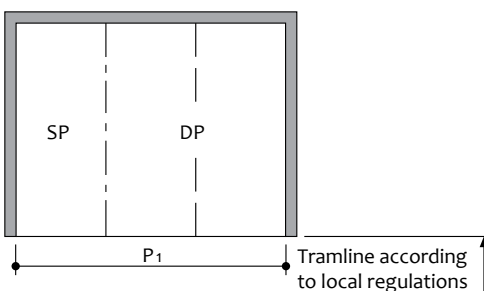

Usable platform width	P1
220+450	730
230+460	750
240+470	770
250+480	790
250+490	810
270+500	830
270+510	840
270+520	850
270+530*	860
270+540*	870

*only N7.1K



HINT: We generally recommend our maximum platform widths of 270 cm for single stages and 520 cm for double stages to 2t, and 540 cm reinforced to 2,6t for edge boxes and boxes with partition walls. Narrower platform widths can cause problems during use (depending on the type of car, access and individual driving behaviour). For large touring limousines and SUVs, tramlines may have to be widened (especially in the case of edge boxes due to the lack of swing radius).

Width dimensions for garage without door (underground car park)

Columns in pit

Single platform (SP)

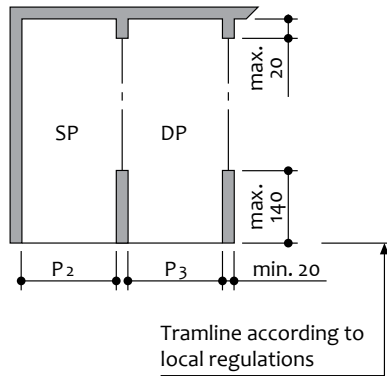

Double platform (DP)

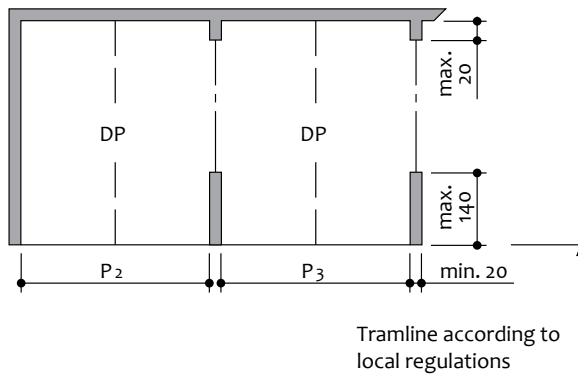

Single and double platform (SP + DP) – Example

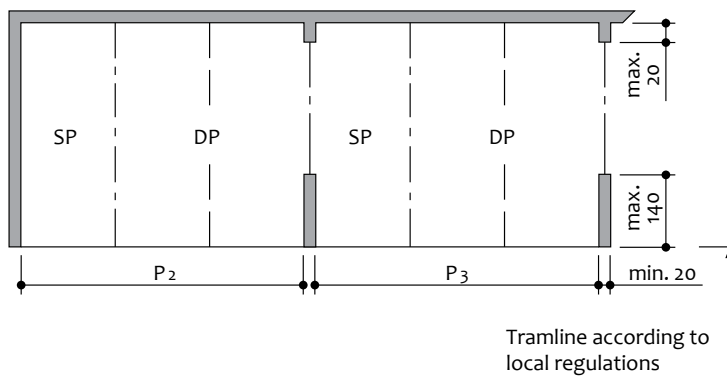

Usable platform width	P2	P3
220	245	235
230	255	245
240	265	255
250	275	265
260	285	275
270	295	285

Usable platform width	P2	P3
450	475	465
460	485	475
470	495	485
480	505	495
490	515	505
500	525	515
510	535	525
520	545	535
530*	555	545
540*	565	555

*only N7.1K

Usable platform width	P2	P3
220+450	725	715
230+460	745	735
240+470	765	755
250+480	785	775
250+490	805	795
270+500	825	815
270+510	835	825
270+520	845	835
270+530*	855	845
270+540*	865	855

*only N7.1K

Page 1
Sections, dimensions, car data

Page 2
Height dimensions

Page 3
Function, Width dimensions divid.walls

Page 4
Width dimensions, columns in pit

Page 5
Width dimensions, columns outside pit

Page 6
Front door termination, Width dimensions

Page 7
Approach Load plan

Page 8
Installation data / electrical installation

Page 9
Technical hint

Page 10
On-site services

Page 11
Description SP + DP



HINT: We generally recommend our maximum platform widths of 270 cm for single stages and 520 cm for double stages to 2t, and 540 cm reinforced to 2,6t for edge boxes and boxes with partition walls. Narrower platform widths can cause problems during use (depending on the type of car, access and individual driving behaviour). For large touring limousines and SUVs, tramlines may have to be widened (especially in the case of edge boxes due to the lack of swing radius).

Width dimensions for garage without door (underground car park)

Columns outside pit

Single platform (SP)

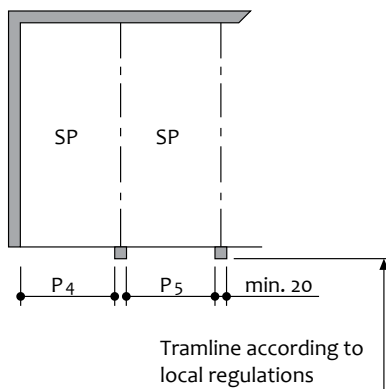

Double platform (DP)

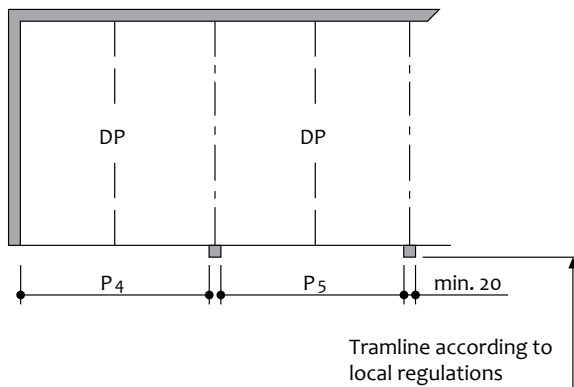

Single and double platform (SP + DP) – Example

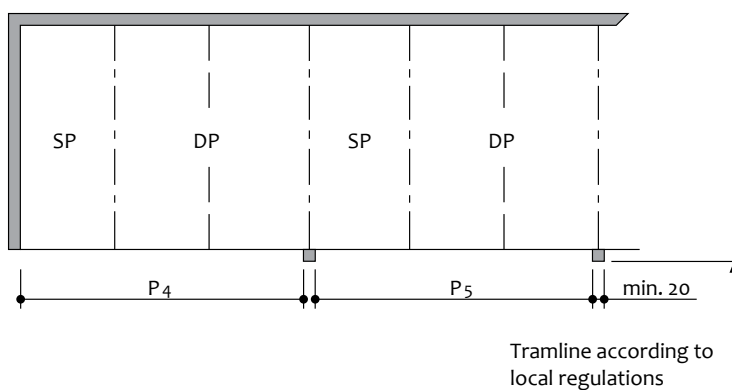

Usable platform width	P4	P5
220	240	230
230	250	240
240	260	250
250	270	260
260	280	270
270	290	280

Usable platform width	P4	P5
450	470	460
460	480	470
470	490	480
480	500	490
490	510	500
500	520	510
510	530	520
520	540	530
530*	550	540
540*	560	550

*only N7.1K

Usable platform width	P4	P5
220+450	720	710
230+460	740	730
240+470	760	750
250+480	780	770
250+490	800	790
270+500	820	810
270+510	830	820
270+520	840	830
270+530*	850	840
270+540*	860	850

*only N7.1K

Page 1
Sections, dimensions, car data

Page 2
Height dimensions

Page 3
Function, Width dimensions divid.walls

Page 4
Width dimensions, columns in pit

Page 5
Width dimensions, columns outside pit

Page 6
Front door termination, Width dimensions

Page 7
Approach Load plan

Page 8
Installation data / electrical installation

Page 9
Technical hint

Page 10
On-site services

Page 11
Description SP + DP



HINT: We generally recommend our maximum platform widths of 270 cm for single stages and 520 cm for double stages to 2t, and 540 cm reinforced to 2,6t for edge boxes and boxes with partition walls. Narrower platform widths can cause problems during use (depending on the type of car, access and individual driving behaviour). For large touring limousines and SUVs, tramlines may have to be widened (especially in the case of edge boxes due to the lack of swing radius).

Garage with door in front of the parking system

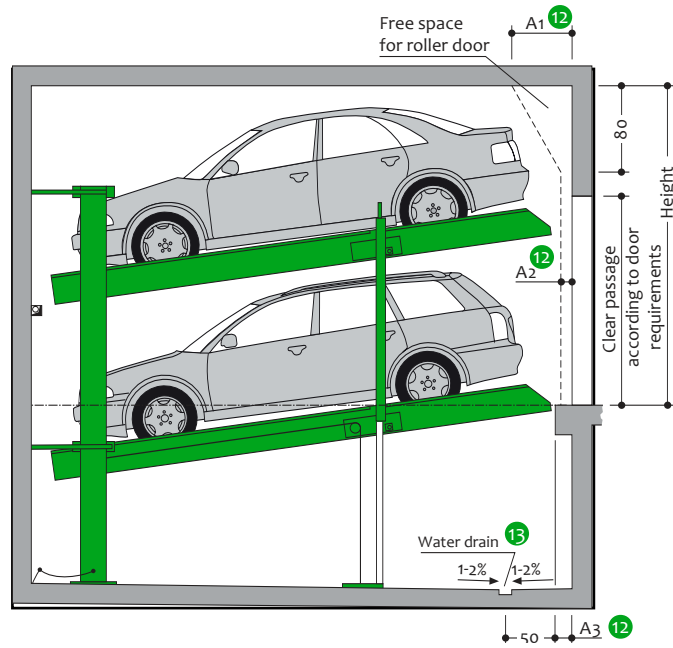

- 12 Dimensions A1, A2 and A3 must be coordinated with the door supplier.
- 13 Slope with drainage channel and sump.

Widths for garage with door in front of car parking system

Single platform (SP)

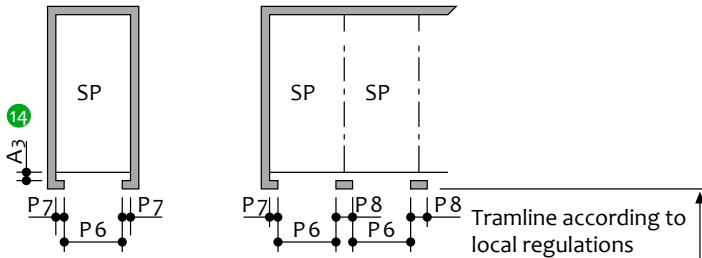

Usable platform width	Door entrance width P6	P7	P8
220	220	15	30
230	237 ⁵	12 ⁵	25
240	250	12 ⁵	25
250	250	15	30
260	260	15	30
270	270	15	30

Double platform (DP)

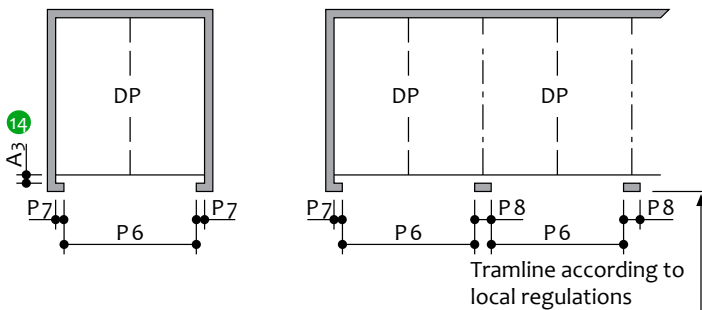

Usable platform width	Door entrance width P6	P7	P8
450	450	15	30
460	460	15	30
470	475	12 ⁵	25
480	475	17 ⁵	35
490	500	12 ⁵	25
500	500	15	30
510	510	15	30
520	520	15	30
530	530	15	30
540	540	15	30

- 14 All-round door dimensions require coordination between door supplier and producer of parking system.



HINT: We generally recommend our maximum platform widths of 270 cm for single stages and 520 cm for double stages to 2t, and 540 cm reinforced to 2,6t for edge boxes and boxes with partition walls. Narrower platform widths can cause problems during use (depending on the type of car, access and individual driving behaviour). For large touring limousines and SUVs, tramlines may have to be widened (especially in the case of edge boxes due to the lack of swing radius).

Page 1
Sections, dimensions, car data

Page 2
Height dimensions

Page 3
Function, Width dimensions divid.walls

Page 4
Width dimensions, columns in pit

Page 5
Width dimensions, columns outside pit

Page 6
Front door termination, Width dimensions

Page 7
Approach Load plan

Page 8
Installation data / electrical installation

Page 9
Technical hint

Page 10
On-site services

Page 11
Description SP + DP

Access incline

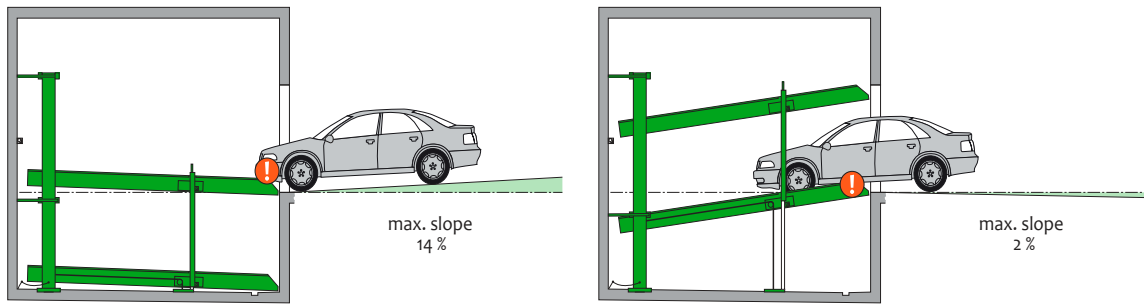

The illustrated maximum approach angles must not be exceeded. Incorrect approach angles will cause serious maneuvering and positioning problems on the parking system for which the producer accepts no responsibility.

Load plan

Forces in kN

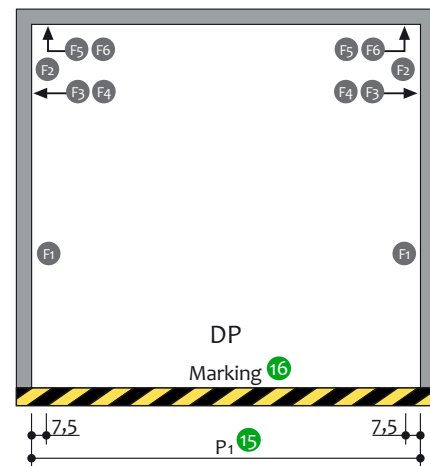
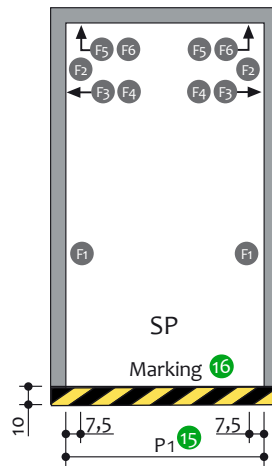
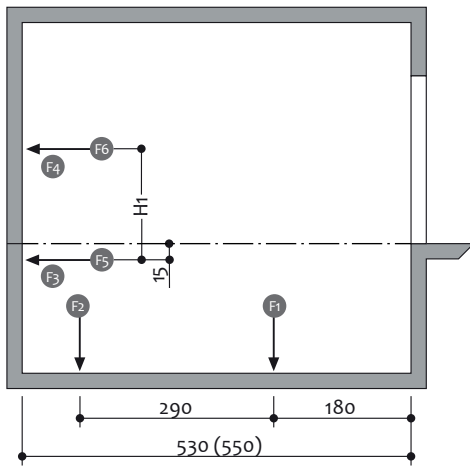

Platform load	F1	F2	F3	F4	F5	F6	17
SP 2000 kg	+28 -1,7	+12	±1	±0,8	±1,9	±1,9	
SP 2600 kg	+36 -2,2	+15	±1,3	±1	±2,4	±2,4	
SP 3000 kg	+42 -2,4	+17	±1,5	±1,2	±2,7	±2,7	
DP 2000 kg	+51 -6,7	+20	±1,6	±2,6	±3,4	±3,4	
DP 2600 kg	+67 -8,6	+26	±2,1	±3,4	±4,4	±4,4	

Type	H1
N7.1-165	150
N7.1-170	155
N7.1-175	160
N7.1-180	165
N7.1-185	170
N7.1-190	175
N7.1-195	180
N7.1-205	190
N7.1-215	200
N7.1-220	205
N7.1-230	215

15 Dimension P1 see page 3

16 Marking according to ISO 3864 (colouring of the image does not correspond to ISO 3864)

17 All forces in kN

HINT: Units are dowelled to the floor. Drilling depth: approx. 15 cm, in the walls approx. 12 cm.

The floor plate and walls must be from concrete (quality min. C20/25).

We generally recommend our maximum platform widths of 270 cm for single stages and 520 cm for double stages to 2t, and 540 cm reinforced to 2,6t for edge boxes and boxes with partition walls. Narrower platform widths can cause problems during use (depending on the type of car, access and individual driving behaviour). For large touring limousines and SUVs, tramlines may have to be widened (especially in the case of edge boxes due to the lack of swing radius).

Page 1
Sections,
dimensions,
car data

Page 2
Height
dimensions

Page 3
Function,
Width
dimensions
divid.walls

Page 4
Width
dimensions,
columns
in pit

Page 5
Width
dimensions,
columns
outside pit

Page 6
Front door
termination,
Width
dimensions

Page 7
Approach
Load plan

Page 8
Installation
data /
electrical
installation

Page 9
Technical
hint

Page 10
On-site
services

Page 11
Description
SP + DP

Installation data

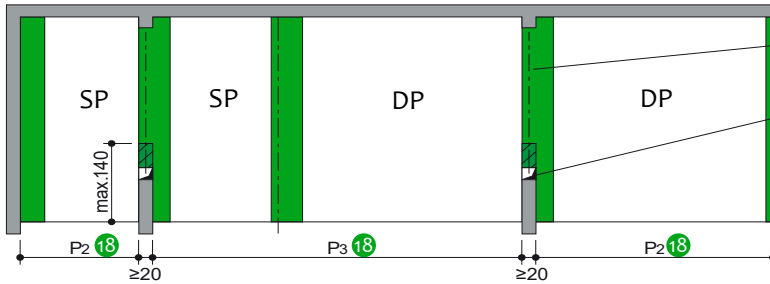
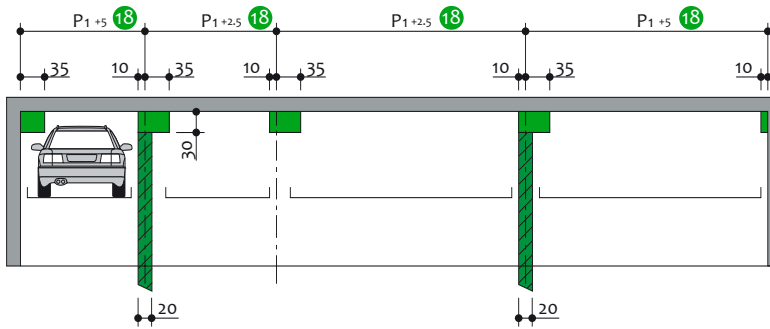

- Free space for vertical pipelines, ventilation ducts
- Clearances for longitudinal guidance

- Page 1** Sections, dimensions, car data
- Page 2** Height dimensions
- Page 3** Function, Width dimensions divid.walls
- Page 4** Width dimensions, columns in pit
- Page 5** Width dimensions, columns outside pit
- Page 6** Front door termination, Width dimensions
- Page 7** Approach Load plan
- Page 8** Installation data / electrical installation
- Page 9** Technical hint
- Page 10** On-site services
- Page 11** Description SP + DP



18 Dimensions P1, P2 and P3 see pages 3,4 and 5.

HINT: Free spaces apply only to forward parked cars with driver exit on the left side!

Electrical installation

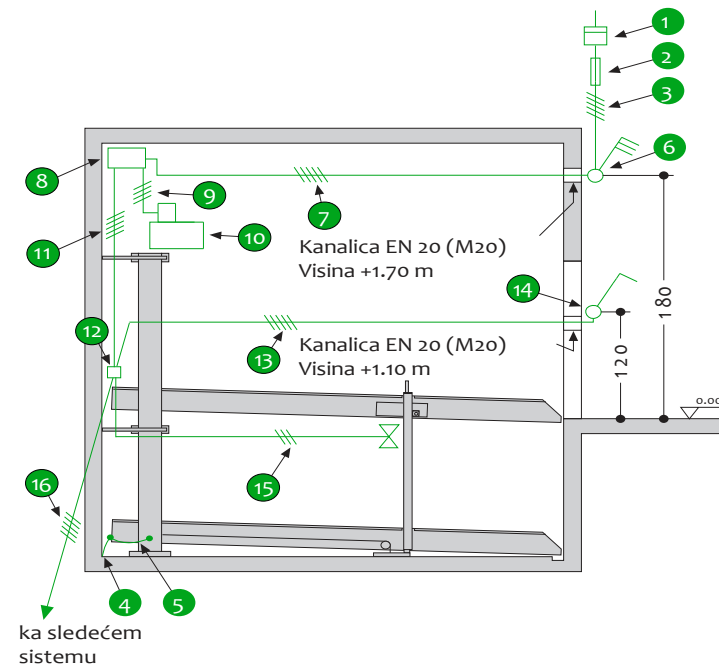

ka sledećem sistemu

Electrical data

included in delivery of producer of parking system

No.	Description
8	Main cabinet
9	Sply cable 5 x 2,5 mm ² 400VAC, with marked wire and protective conductor
10	Hydraulic unit 3,0 kW/5,2 kW, 3 phase 400 V/50 Hz
11	Control line 5 x 1,5 mm ² 24VDC, with marked wire and protective conductor
12	Distribution unit
13	Control line 5 x 1,5 mm ² 24VDC, with marked wire and protective conductor
14	Key switch, 2 way momentary with emergency stop
15	Control line 3 x 0,75 mm ² 24VDC, with marked wire and protective conductor
16	Connection cable to the next system 5 x 1,5 mm ² with marked wire and protective conductor

Electrical data

to be performed by the customer

No.	Qty.	Description	Position	Frequency
1	1	Power meter	in the supply line	
2	1	Pre-fuse: 3x safety fuse 16 A (slow-blow) or Circuit breaker 3x16 A (trip characteristic K or C)	in the supply line	1 per 3,0 kW unit
		3x safety fuse 20A (slow-blow) or Circuit breaker 3x20 A (trip characteristic K or C)	in the supply line	1 per 5,2 kW unit
3	1	Supply line 5 x 2.5mm ² (3 PH + N + PE) with marked wire and protective conductor	to main switch	1 per unit
4	1	Lockable main switch	defined by the project	1 per unit
5	1	Supply line 5 x 2.5mm ² (3 PH + N + PE) with marked wire and protective conductor	from main switch to main cabinet	1 per unit
6	1	Potential equalization from foundation grounding connection system according to DIN EN 60204		1 per system
7	every 10 m	Foundation earth connector	corner pit floor	

Technical hint**Application area**

By default, the system is not suitable for short-term parkers (changing users). If necessary, please contact producer of parking system.

Power pack

Installed on vibration metal mounted, low-noise hydraulic power units. Nevertheless, we recommend separating the garage from the house.

Available documents

- Wall recess plans
- Maintenance offer/contract
- Declaration of conformity

Corrosion protection

According to the supplementary sheet of corrosion protection.

Balustrade / Barriers

When the allowable fall is exceeded, balustrades are attached to the equipment. If the traffic lanes are directly next to or behind the installations, barriers according to DIN EN 294 (DIN EN ISO 13857) are required on site. This also applies during the construction phase.

Environmental conditions

Ambient conditions for the range of our parking systems: Temperature range -10 to +40° C. Relative humidity 50% with a maximum outside temperature of +40° C. If lifting or lowering durations are mentioned, these refer to an ambient temperature of +10° C and an arrangement of the system immediately next to the hydraulic unit. At lower temperatures or longer hydraulic lines, these durations increase.

Soundproofing

According to DIN 4109 (sound insulation in building construction), para. 4, note 4, parking systems fall into the field of technical installations (garage systems).

Normal sound insulation (Special agreement) DIN 4109, Supplement 4, Note for planning and execution, proposals for increased sound insulation. In paragraph 4.1, Table 4, the values for the permissible sound pressure levels in rooms requiring protection are specified for noise from building services. According to line 2, the maximum sound pressure level in living rooms and bedrooms must not exceed 30 dB (A). Noise from the user is not subject to the requirements (see Table 4, DIN 4109).

The following measures are required to maintain this value:

- Soundproofing package according to offer/order
- Sound insulation of the building in min. $R'w = 57$ dB (performance on site)

Increased sound insulation

DIN 4109, paragraph 4, noise protection of technical equipment and installations.

Agreement: Maximum sound pressure level in living rooms and bedrooms 25 dB (A). User noises are not subject to the requirements (see Table 4, DIN 4109).

The following measures are required to maintain this value:

- Soundproofing package according to offer/order
- Sound insulation of the building in min. $R'w = 62$ dB (performance on site)



HINT: The user's noises are essentially noises that can be individually influenced by the user of our parking systems. These include for example driving on the platform, slamming vehicle doors, engine noise and brake.

Page 1Sections,
dimensions,
car data**Page 2**Height
dimensions**Page 3**Function,
Width
dimensions
divid.walls**Page 4**Width
dimensions,
columns
in pit**Page 5**Width
dimensions,
columns
outside pit**Page 6**Front door
termination,
Width
dimensions**Page 7**Approach
Load plan**Page 8**Installation
data /
electrical
installation**Page 9**Technical
hint**Page 10**On-site
services**Page 11**Description
SP + DP

To be performed by the customer

Balustrade / Barriers

Possibly required barriers according to DIN 294 for securing the parking pits in traffic lanes directly in front of, beside or behind the facilities. This also applies during the construction phase. Railings on the systems, if required, are included optional!

Numbering of parking spaces

Continuous numbering of parking spaces.

Building services

Lighting, ventilation, fire extinguishing and fire alarm systems.

Drainage

In the front of the pit, we recommend to plan a water collecting gutter and to connect it to a ground drain or a pit (50 x 50 x 20 cm) In the canal, a lateral slope is possible, but not in the remaining area of the pit (the gradient in the longitudinal direction is due to the dimensions). In the interest of environmental protection, a painting of the bottom of the pit should be made. Oil or gas separators are recommended for connection to the sewer system.

Marking

In accordance with DIN EN 14 010, a warning mark must be affixed to the access zone to identify this danger zone in accordance with ISO 3864. The design shall be in accordance with EN 92/58/EEC for installations with a pit (platforms inside the pit) 10 cm from the edge of the pit.

Wall openings

Possibly required wall openings according to sectional drawings on page 1.

Electrical supply to the control box/Foundation earth connector

The supply line to the main switch and the control line to the unit must be made by the customer during installation. The functionality can be checked by our technicians on site together with the electrician. If this is not possible during assembly for reasons attributable to the customer, an electrician must be commissioned by the customer. The steel construction is to be provided on site with foundation earthing connection (grounding distance max 10 m) and potential equalization according to DIN EN 60204.

Control panel

Empty conduits and cut-outs for the control element (with hinged doors, a prior consultation with producer of parking system is necessary).

Control panel on plaster

Control panel under plaster

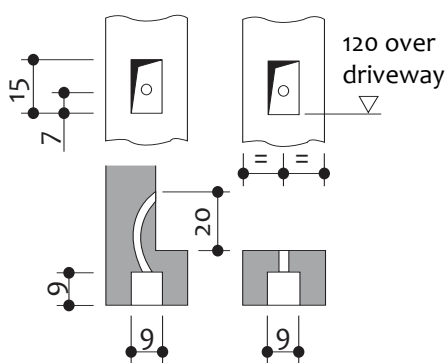
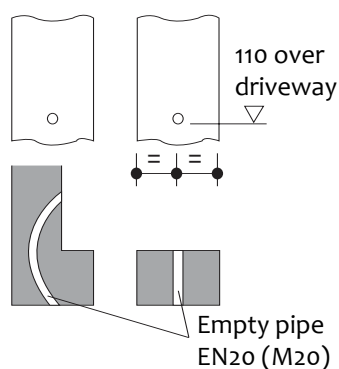

The following costs must be supported by the customer, if they are not included in the offer:

- Complete wiring of the individual components according to the wiring diagram
- Cost of final technical approval by an authorized expert
- Main switch
- Control line from the main switch to the control cabinet
- Railing
- Floor marking

Page 1
Sections, dimensions, car data

Page 2
Height dimensions

Page 3
Function, Width dimensions divid.walls

Page 4
Width dimensions, columns in pit

Page 5
Width dimensions, columns outside pit

Page 6
Front door termination, Width dimensions

Page 7
Approach Load plan

Page 8
Installation data / electrical installation

Page 9
Technical hint

Page 10
On-site services

Page 11
Description SP + DP

Description single platform (SP) and double platform (DP)**General description**

- The parking system provides independent parking spaces of 2 cars (SP), 2x2 cars (DP) on top of each other
- Dimensions according to the underlying pit, width and height dimensions
- The upper parking bays are accessed inclined (approx. 2° ascending slope), the lower parking bays are accessed inclined (approx. 8° descending slope), installation deviation ± 1%
- By special arrangement of the lifting and supporting structure, the opening of the doors is not restricted
- Passenger car positioning on each parking space by means of a positioning aid mounted on the right-hand side (to be set in accordance with the operating instructions)
- Operation via a control element with automatic reset by means of a key that closes the same way
- Fixing the control element usually in front of the support or on the way revealing the outside
- Operating instructions at every operating point
- For garages with an entrance door, special dimensions must be respected

The parking system consists of:

- 2 Pillars with foundation rails (fixed to the floor)
- 2 Sliding pieces (with sliding guides attached to the pillars)
- 2 Platforms
- 1 mechanical synchronization system (for the synchronous operation of the hydraulic cylinders during lifting and lowering)
- 2 Hydraulic cylinders
- 2 rigid supports (connection of the platforms)
- 1 automatic hydraulic breakage protection (prevents involuntary lowering when driving on)
- Dowels, screws, fasteners, bolts etc.

Platform consisting of:

- Platform profiles
- Adjustable positioning aids
- Beveled bumpers
- Lateral beams
- Bearing center [DP only]
- Brackets
- Screws, nuts, spacer tubes, etc.

Hydraulics consisting of:

- Hydraulic cylinder
- Magnetic valve
- Line break security
- Hydraulic lines
- Fittings
- High pressure hoses
- Mounting material

Electrics consisting of:

- Control element (EMERGENCY STOP, lock, 1 key with the same key per parking space)
- Sub-distribution
- Control cabinet

Hydraulic unit consisting of:

- Hydraulic unit (low noise, mounted on bracket)
- Hydraulic oil tank
- Oil filling
- Internal gear pump
- Pump support
- Coupling
- Three-phase motor (3.0 kW/5.2 kW/400 V, 50 Hz)
- Pressure gauge
- Pressure relief valve
- Hydraulic hoses (to dampen noise transmission on hydraulic pipes)

We reserve the right to change these specifications without prior notice

Manufacturer reserves the right in the course of the technical progress to use newer or other technologies, system, processes, procedures or standards in the fulfillment of their obligations other than those originally offered.

Page 1
Sections,
dimensions,
car data**Page 2**
Height
dimensions**Page 3**
Function,
Width
dimensions
divid.walls**Page 4**
Width
dimensions,
columns
in pit**Page 5**
Width
dimensions,
columns
outside pit**Page 6**
Front door
termination,
Width
dimensions**Page 7**
Approach
Load plan**Page 8**
Installation
data /
electrical
installation**Page 9**
Technical
hint**Page 10**
On-site
services**Page 11**
Description
SP + DP