

level Park

PARKING SYSTEMS

SERBIA

PRODUCT DATA

Dimensions, technical data
and specifications

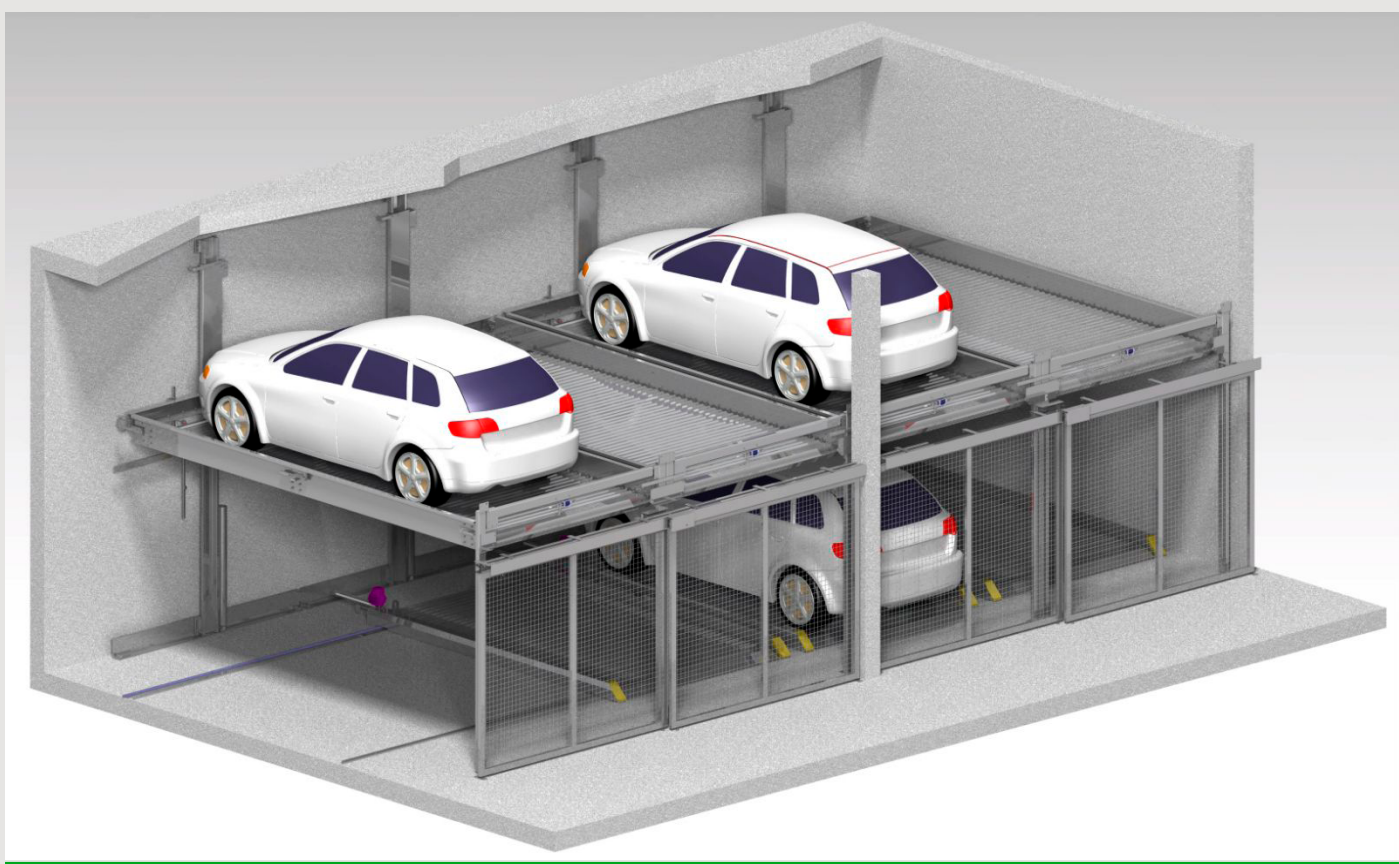

smart02



www.levelpark-rs.com



E-mail sales@levelpark-rs.com
 Internet www.levelpark-rs.com

Smarto1 (Smarto1R) Semi-automatic parking system

Dimensions

All space requirements are minimum finished dimensions. Tolerances for space requirements ¹³ ①

Standard passenger car (L)

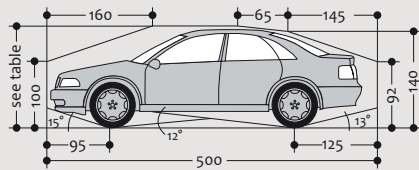

Standard station wagon (K)

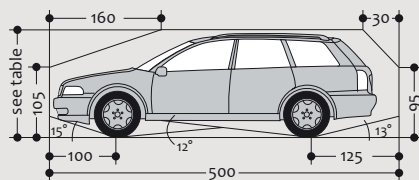

Standard passenger cars are vehicles without any sports options such as spoilers, low-profile tires, etc.

Parking possibilities

	Standard Smarto2	Reinforced Smarto2R
Width in cm	190 ②	190 ②
Weight in kg	max.2000	max.2600
Wheel load in kg	max.500	max. 650

Specification

- Independent parking
- Grid arrangement
 - Minimum 2 grids for 3 vehicles
 - Maximum 10 grids
- Vehicle height up 150 cm to 245 cm
- Vehicle length up 500 cm to 520 cm
- Smarto2 (Standard):
Load capacity 2000 kg per parking space, usable platform width up to 270 cm
- Smarto2R (Reinforced):
Load capacity 2600 kg per parking space, usable platform width up to 270 cm



The systems provided are consistent with DIN EN 14010, the VDMA 15423 spec. and the EC Machinery Directive 2006/42/EC.



Platforms accessible horizontally.



Max. load per parking space in kg.



Upweighting over 2000 kg possible with surcharge.



Parking space load can be subsequently upweighted.

Prikaz garaže bez vrata

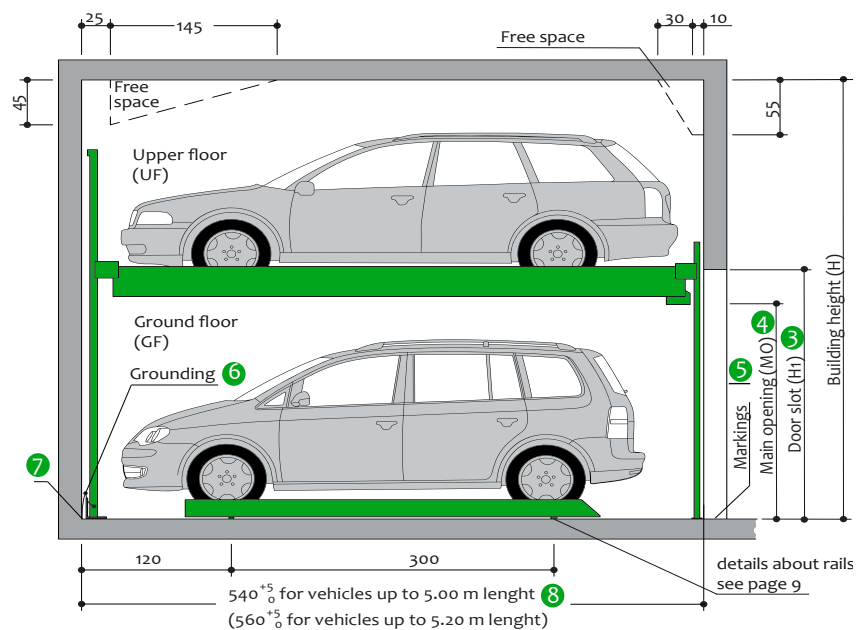

Napomene

- ① To comply with the minimum finished dimensions, the tolerances according to VOB, Part C (DIN 18330 and 18331) and DIN 18202 must also be considered.
- ② Car width for platform width 230 cm. For the greatest possible ease-of-use, we recommend platforms up 250 to 270 cm.
- ③ If a higher ceiling height is available, higher cars can be parked. Dimensions depend on the type and size of the door. The door should be selected in accordance with DIN EN 14010.
- ④ MO (main opening) Must be at least as large as the maximum height of the car + 5 cm.
- ⑤ In accordance with DIN EN 14010, the customer must place 10 cm wide yellow-black markings in accordance with ISO 3864 on the edge of the pit in the entry zone to mark the danger zone.
- ⑥ Grounding of the system to be connected to the central grounding on-site (to be provided by the customer).
- ⑦ At the transition section between the pit floor and walls, no hollow mouldings/coves are possible. If hollow mouldings/coves are required, the systems must be designed smaller or the pits wider.
- ⑧ For convenient use of your parking space and due to the fact that the cars keep becoming longer we recommend a pit length of 570 cm.



If sprinklers are required, make sure to provide the necessary free spaces during the planning stage.

Page 1

Sections, dimensions, car data

Page 2

Variants and Height dimensions

Page 3

Width dimensions without garage doors

Page 4

Width dimensions pillars position

Page 5

Width dimensions pillars position

Page 6

Width dimensions roll door

Page 7

Rails width dimensions tolerances

Page 8

Access incline Load plan

Page 9

Installation function numbering

Page 10

Electrical installation

Page 11

Technical hint

Page 12

To be performed by the customer

Page 13

Technical description

Overview of system types and ceiling heights

The permitted vehicle height on ground floor must be equal or higher than the vehicle height on upper floor!

Standard

Smart02-175

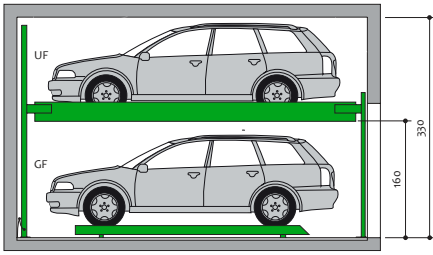

Height	Vehicle height	
	GF	UF
330	150	150

Smart02-200

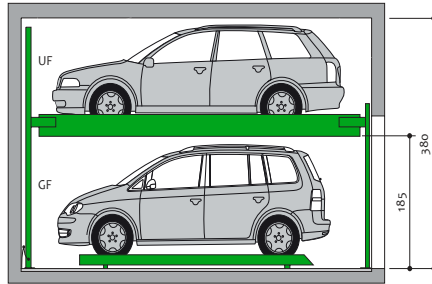

Height	Vehicle height	
	GF	UF
380	175	175

Smart02-230

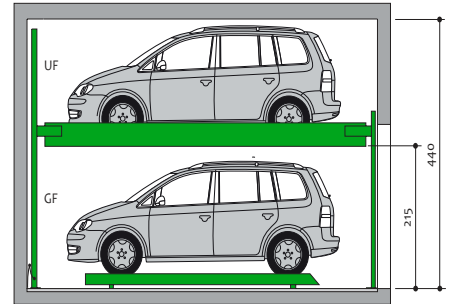

Height	Vehicle height	
	GF	UF
440	205	205

Available on request

Type	Main opening	Vehicle height
	MO	GF
Smart02-160	160	150
Smart02-175	175	165
Smart02-180	180	170
Smart02-185	185	175
Smart02-210	210	200
Smart02-215	215	205

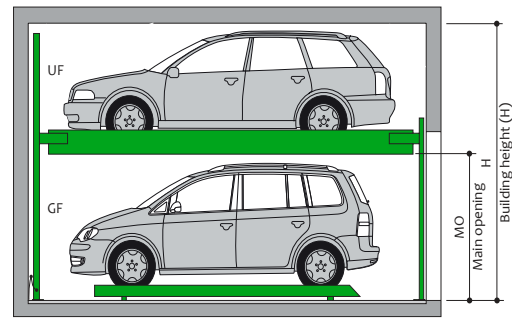

Vehicle height GF	Vehicle height UF											H - Buildint height	
	150	155	160	165	170	175	180	185	190	195	200		205
150	330	-	-	-	-	-	-	-	-	-	-	-	-
165	345	350	355	360	-	-	-	-	-	-	-	-	-
170	350	355	360	365	370	-	-	-	-	-	-	-	-
175	355	360	365	370	375	380	-	-	-	-	-	-	-
200	380	385	390	395	400	405	410	415	420	425	430	-	-
205	385	390	395	400	405	410	415	420	425	430	435	440	-

Example configuration

Example configuration 1:

Vehicle GF: 170
Vehicle UF: 160
Type: **Smart02-180**
Height: **360**

Example configuration 2:

Vehicle GF: 175
Vehicle UF: 185
Type: **Smart02-185**
Height: **Selection not possible!**

Configuration 2 is not possible as the maximum permissible vehicle on GF is smaller than the vehicle on UF. As such, the larger vehicle, UF cannot drive in.



The permitted height of vehicles on the ground floor must be equal to or greater than the height of vehicles on the upper level!

Page 1
Sections, dimensions, car data

Page 2
Variants and Height dimensions

Page 3
Width dimensions without garage doors

Page 4
Width dimensions pillars position

Page 5
Width dimensions pillars position

Page 6
Width dimensions roll door

Page 7
Rails width dimensions tolerances

Page 8
Access incline Load plan

Page 9
Installation function numbering

Page 10
Electrical installation

Page 11
Technical hint

Page 12
To be performed by the customer

Page 13
Technical description

Width dimensions without sliding garage doors

Standard model without garage door

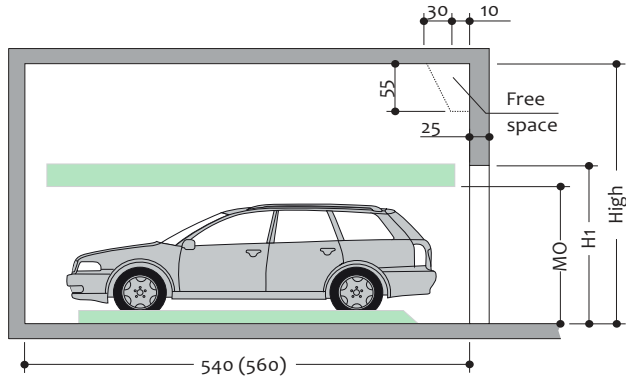

Vehicle height (GF)	Entrance height (H1)
150	210
155	210
160	210
165	210
170	210
175	210
180	210
185	210
190	210
195	210
200	215
205	220

Standard model without garage door, columns per each grid unit

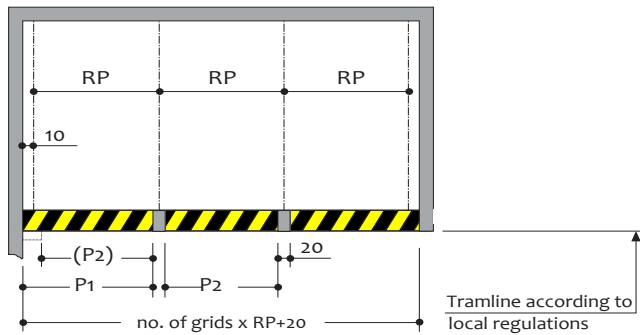

Usable platform width		Grid width (RP)	Garage width	
UF	GF		P1	P2
230	220	250	250	230
240	230	260	260	240
250	250	270	270	250
260	250	280	280	260
270	260	290	290	270

Standard model without garage door, columns every second grid unit

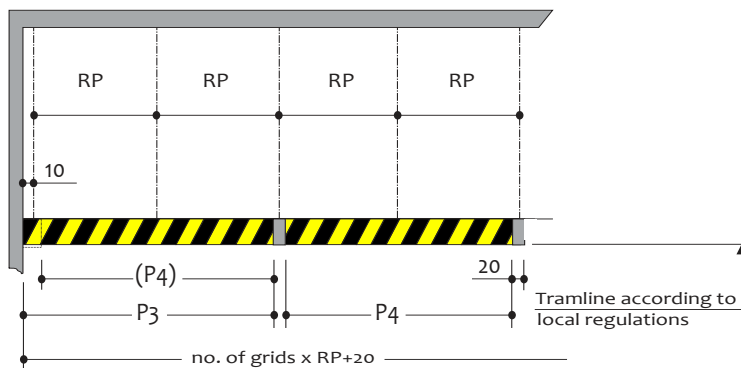

Usable platform width		Grid width (RP)	Garage width	
UF	GF		P3	P4
230	220	250	500	480
240	230	260	520	500
250	250	270	540	520
260	250	280	560	540
270	260	290	580	560



According to ASR A1.7, an inspection book is required for a door with electric drive of commercial use. Before commissioning and annually thereafter, the door must be inspected by an expert and the result entered in the inspection book. The inspection must be done independently of any maintenance.



HINT: The outer parking spaces (closer to the wall) are generally more difficult to park. Parking on standard platform widths with larger vehicles can be difficult. This depends on the type of vehicle, the approach to the platforms and above all the individual driving skills and experience. For maximum comfort, we recommend a maximum platform width of 250 to 270 cm.

Page 1
Sections, dimensions, car data

Page 2
Variants and Height dimensions

Page 3
Width dimensions without garage doors

Page 4
Width dimensions pillars position

Page 5
Width dimensions pillars position

Page 6
Width dimensions roll door

Page 7
Rails width dimensions tolerances

Page 8
Access incline Load plan

Page 9
Installation function numbering

Page 10
Electrical installation

Page 11
Technical hint

Page 12
To be performed by the customer

Page 13
Technical description

Width dimensions with sliding garage doors

Sliding door behind the columns

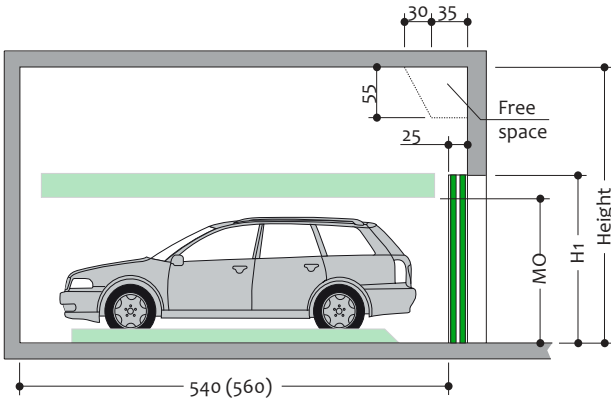

Vehicle height (GF)	Entrance height (H1)
150	210
155	210
160	210
165	210
170	210
175	210
180	210
185	210
190	210
195	210
200	215
205	220

Sliding door behind the columns, columns per each grid unit

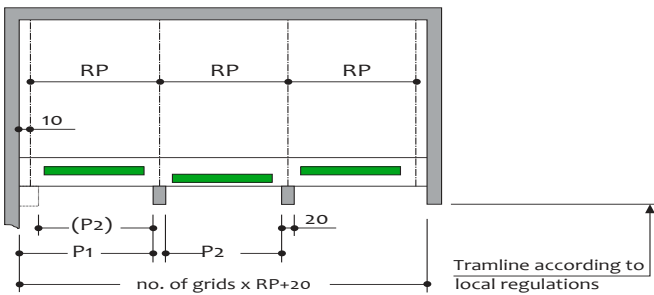

Usable platform width		Grid width (RP)	Garage width	
UF	GF		P1	P2
230	220	250	250	230
240	230	260	260	240
250	250	270	270	250
260	250	280	280	260
270	260	290	290	270

Sliding door behind the columns, columns every second grid unit

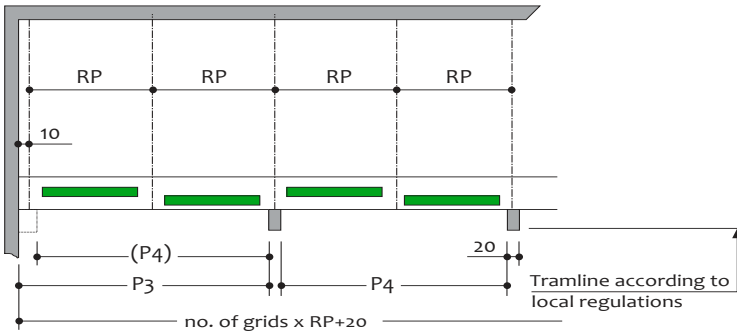

Usable platform width		Grid width (RP)	Garage width	
UF	GF		P3	P4
230	220	250	500	480
240	230	260	520	500
250	250	270	540	520
260	250	280	560	540
270	260	290	580	560

Sliding door between columns

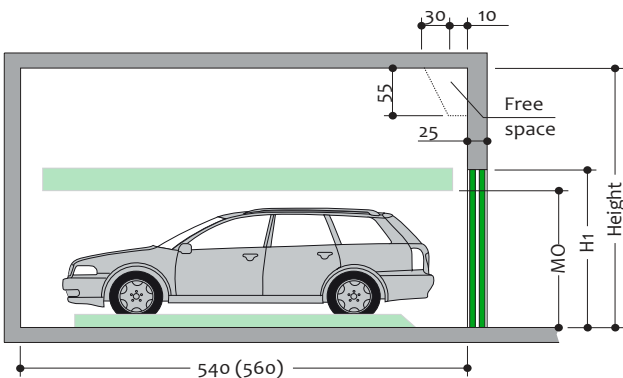

Vehicle height (GF)	Entrance height (H1)
150	220
155	220
160	220
165	220
170	220
175	220
180	220
185	220
190	220
195	220
200	225
205	230

Sliding door between columns, columns per each grid unit



Option not possible!

HINT: The outer parking spaces (closer to the wall) are generally more difficult to park. Parking on standard platform widths with larger vehicles can be difficult. This depends on the type of vehicle, the approach to the platforms and above all the individual driving skills and experience. For maximum comfort, we recommend a maximum platform width of 250 to 270 cm.

Page 1
Sections, dimensions, car data

Page 2
Variants and Height dimensions

Page 3
Width dimensions without garage doors

Page 4
Width dimensions pillars position

Page 5
Width dimensions pillars position

Page 6
Width dimensions roll door

Page 7
Rails width dimensions tolerances

Page 8
Access incline Load plan

Page 9
Installation function numbering

Page 10
Electrical installation

Page 11
Technical hint

Page 12
To be performed by the customer

Page 13
Technical description

Width dimensions with sliding garage doors

Sliding door between columns, columns every second grid unit

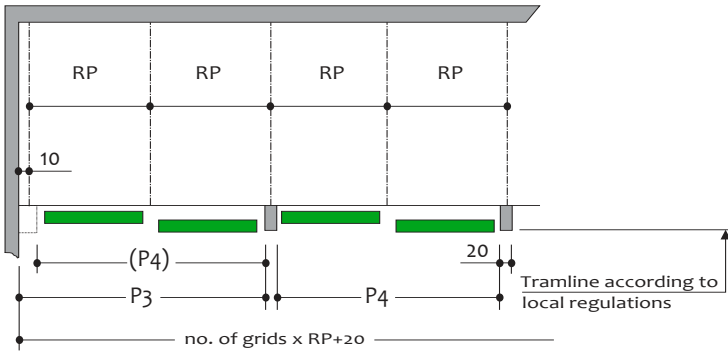

Usable platform width		Grid width (RP)	Garage width	
UF	GF		P3	P4
230	220	250	500	480
240	230	260	520	500
250	250	270	540	520
260	250	280	560	540
270	260	290	580	560

Sliding door in front of columns

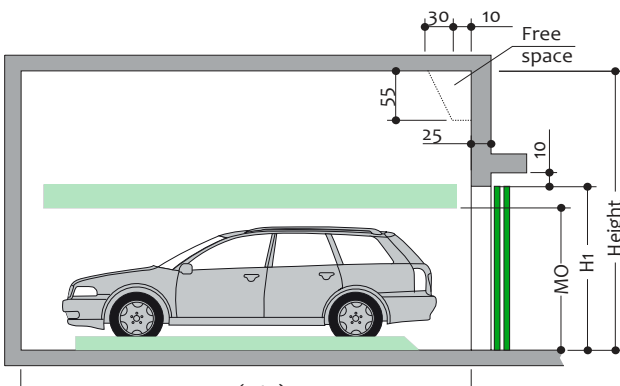

Vehicle height (GF)	Entrance height (H1)
150	210
155	210
160	210
165	210
170	210
175	210
180	210
185	210
190	210
195	210
200	215
205	220

Sliding door in front of columns, columns per each grid unit

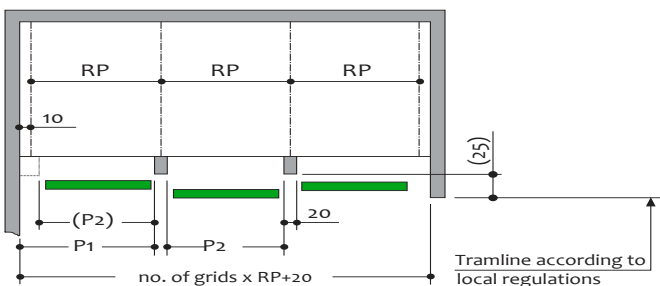

Usable platform width		Grid width (RP)	Garage width	
UF	GF		P1	P2
230	220	250	250	230
240	230	260	260	240
250	250	270	270	250
260	250	280	280	260
270	260	290	290	270

Sliding door in front of columns, columns every second grid unit

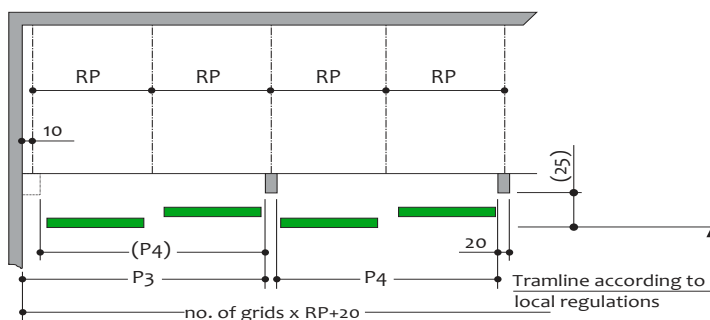

Usable platform width		Grid width (RP)	Garage width	
UF	GF		P3	P4
230	220	250	500	480
240	230	260	520	500
250	250	270	540	520
260	250	280	560	540
270	260	290	580	560

Page 1
Sections, dimensions, car data

Page 2
Variants and Height dimensions

Page 3
Width dimensions without garage doors

Page 4
Width dimensions pillars position

Page 5
Width dimensions pillars position

Page 6
Width dimensions roll door

Page 7
Rails width dimensions tolerances

Page 8
Access incline Load plan

Page 9
Installation function numbering

Page 10
Electrical installation

Page 11
Technical hint

Page 12
To be performed by the customer

Page 13
Technical description



HINT: The outer parking spaces (closer to the wall) are generally more difficult to park. Parking on standard platform widths with larger vehicles can be difficult. This depends on the type of vehicle, the approach to the platforms and above all the individual driving skills and experience. For maximum comfort, we recommend a maximum platform width of 250 to 270 cm.

Width dimensions, garages with roll doors

Roll door behind columns

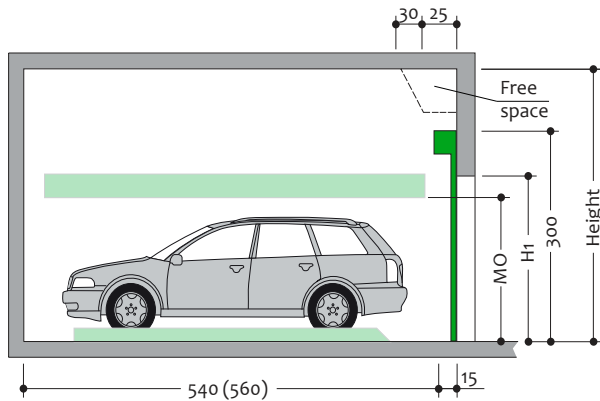

Vehicle height (GF)	Entrance height (H1)
150	220
155	220
160	220
165	220
170	220
175	220
180	220
185	220
190	220
195	220
200	225
205	230

Roll door behind columns, columns per each grid unit

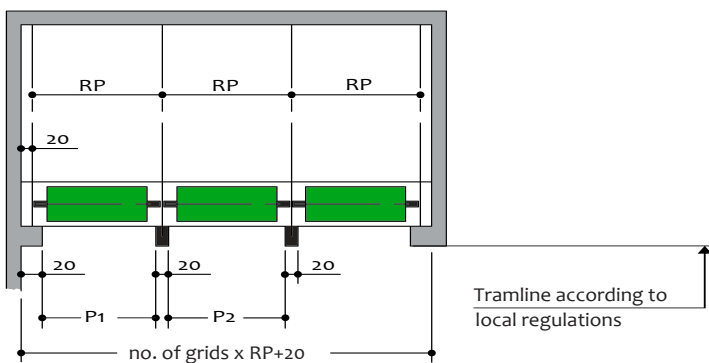

Usable platform width		Grid width (RP)	Garage width	
UF	GF		P1	P2
230	220	250	250	230
240	230	260	260	240
250	250	270	270	250
260	250	280	280	260
270	260	290	290	270

Wall clearance

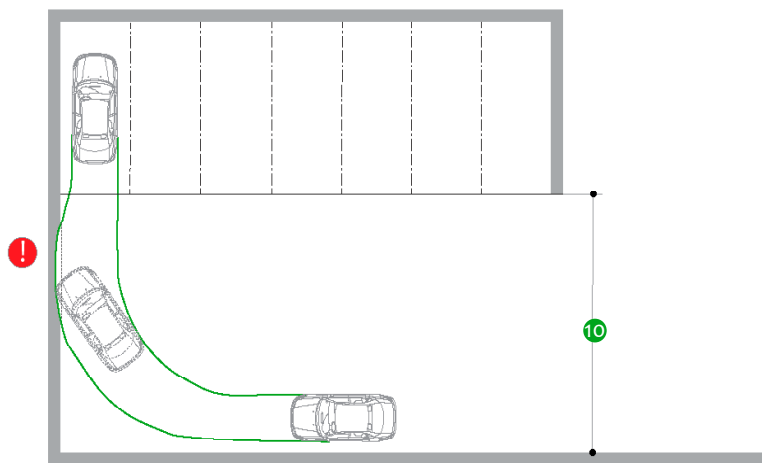

Narrower platforms may impede parking according to the following criteria.



- Driving lane width
- Entrance conditions
- Vehicle dimensions

10 Observe minimum driving lane width in accordance with local regulations!



HINT: The outer parking spaces (closer to the wall) are generally more difficult to park. Parking on standard platform widths with larger vehicles can be difficult. This depends on the type of vehicle, the approach to the platforms and above all the individual driving skills and experience. For maximum comfort, we recommend a maximum platform width of 250 to 270 cm.

Page 1
Sections, dimensions, car data

Page 2
Variants and Height dimensions

Page 3
Width dimensions without garage doors

Page 4
Width dimensions pillars position

Page 5
Width dimensions pillars position

Page 6
Width dimensions roll door

Page 7
Rails width dimensions tolerances

Page 8
Access incline Load plan

Page 9
Installation function numbering

Page 10
Electrical installation

Page 11
Technical hint

Page 12
To be performed by the customer

Page 13
Technical description

Recess / Rail system

Dependent upon the structural conditions of the garage, several different options are available for installation of the rails.

Laying on strip foundation ¹¹

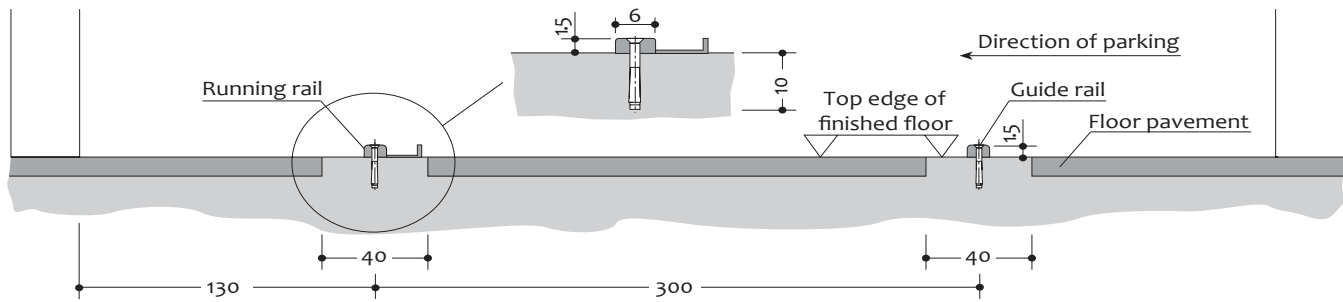

Laying on finished floor ¹¹

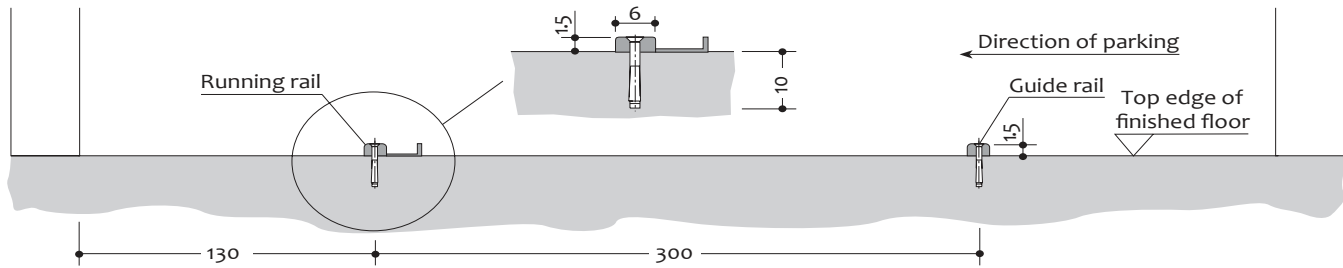

¹¹ Screed to be concrete.

Evenness and Tolerances (abstract from DIN 18 202, table 3)

The distance between the lower flange of the platforms and the garage ground must therefore not exceed 2 cm. To adhere to the safety regulations and DIN EN 14 010 recommendations and to get the necessary even ground, the tolerances of evenness to DIN 18202, table 3, line 3, must not be exceeded. Therefore exact levelling of the ground by the client is essential.

Column	1	2	3	4	5	6
Line	Reference	¹² Vertical measurement as limits in mm with measuring points distances in m to				
2	Unfinished to surface of covers, subconcrete and subsoils for higher demands, e.g. as foundation for cast plaster floor, industrial soils, paving tiles and slabstone paving, compound floor paving.	0,1	1	4	10	15
3	Finished surfaces for minor purposes, e.g. warehouses, cellar. Finished grounds, e.g. floor pavement serving as foundation for coverings. Coverings, tile coverings, PVC flooring and glued coverings.	5	8	12	15	20
		2	4	10	12	15

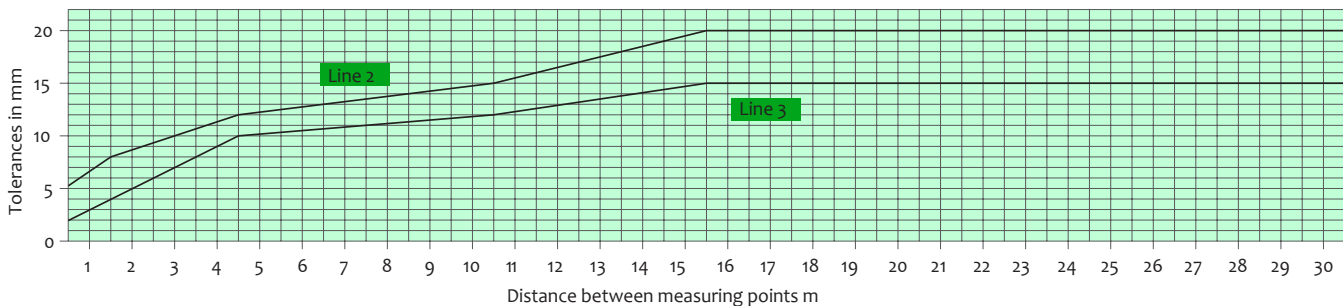

¹² Intermediate values are to be taken out the diagram and must be rounded-off to mm.

Page 1
Sections, dimensions, car data

Page 2
Variants and Height dimensions

Page 3
Width dimensions without garage doors

Page 4
Width dimensions pillars position

Page 5
Width dimensions pillars position

Page 6
Width dimensions roll door

Page 7
Rails width dimensions tolerances

Page 8
Access incline Load plan

Page 9
Installation function numbering

Page 10
Electrical installation

Page 11
Technical hint

Page 12
To be performed by the customer

Page 13
Technical description

Access incline

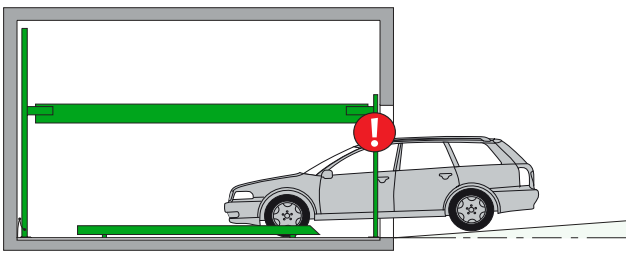

Maximum descending slope 3 %

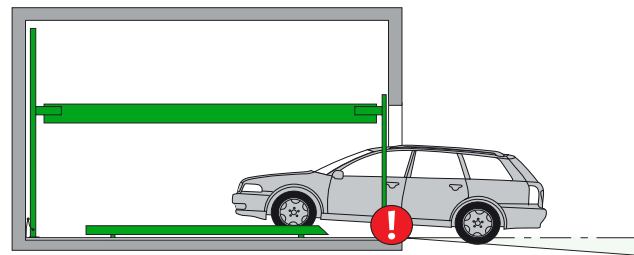

Maximum ascending slope 5 %



The illustrated maximum approach angles must not be exceeded. Incorrect approach angles will cause serious maneuvering and positioning problems on the parking system for which the producer accepts no responsibility.

Load plan

Load plan - cross section

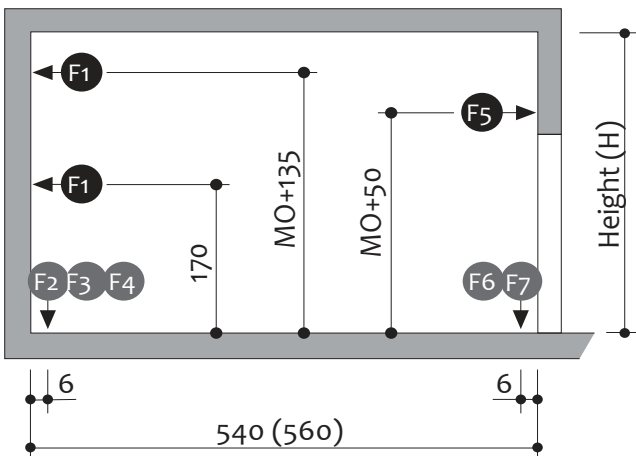

MO: see page 1

Dimensions for support points are rounded values.

If exact positioning is required, please contact Level Park.

Load plan - top view

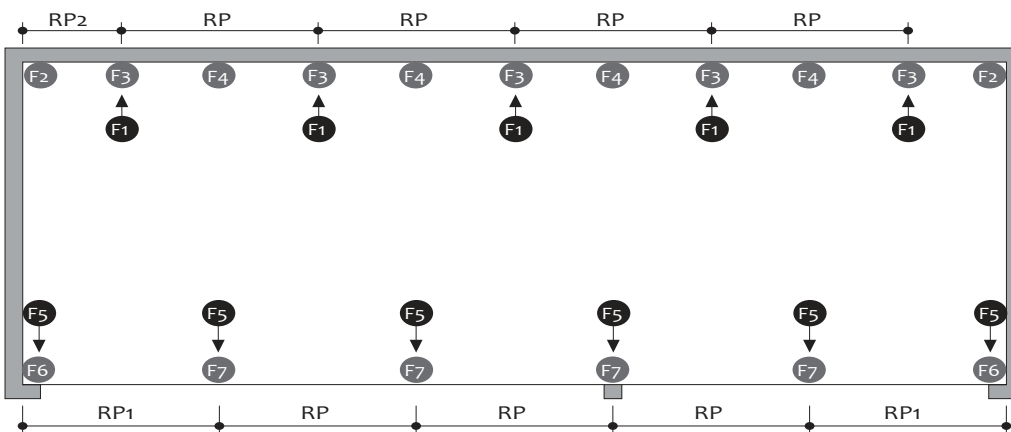

Usable platform width	Grid width		
	RP	RP1	RP2
230	250	260	135
240	260	270	140
250	270	280	145
260	280	290	150
270	290	300	155

Platform load	Force (kN)						
	F1	F2	F3	F4	F5	F6	F7
2000 kg	±2	-9	+38	-18	approx.+0,5	+9 -7	+18 -14
2600 kg	±2	-11	+41	-22	approx.+0,5	+12 -10	+24 -20



HINT: The systems are dowelled into the ground. The drill hole depth in the floor plate is approx. 15 cm, in the walls approx. 12 cm. **The floor plate and walls must be from concrete (quality min. C20/25).** The dimensions for the bearing points have been rounded. If the precise figures are required, please consult manufacturer.

Installation data

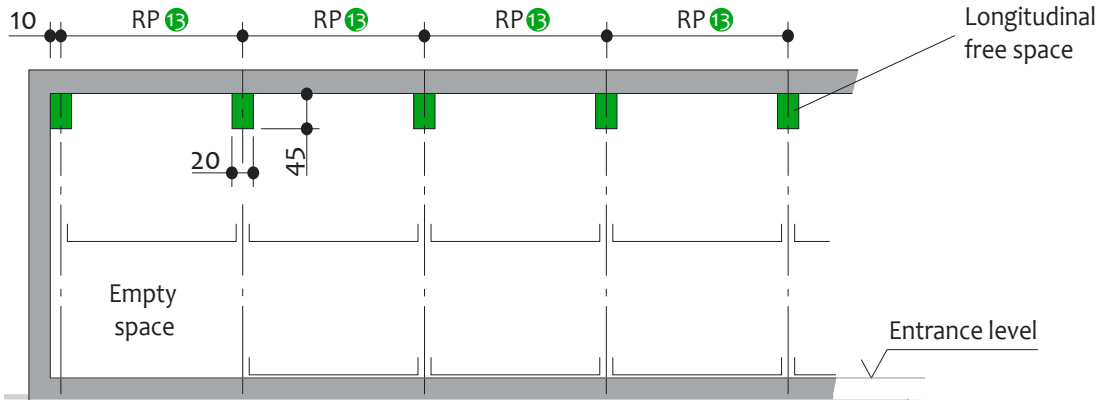

HINT: Free spaces apply only to forward parked cars with driver exit on the left side!

13 Dimensions RP see pages 3,4 and 5.

Function with standard numbering and identification of parking levels

e.g. for parking space No. 4:

Check first that all doors are closed, and then place the RFID key for parking space number 4 on the control panel.

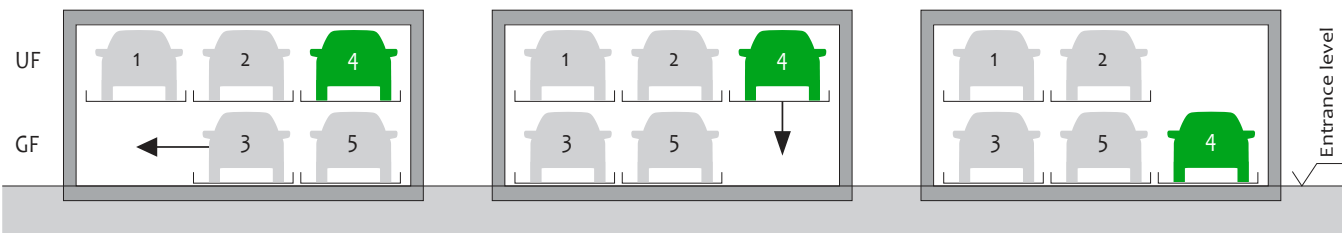

For driving the vehicle off platform no.4, the ground floor parking platforms are shifted to the left.

The empty space is now below the vehicle which shall be driven off the platform. Platform no.4 will be lowered.

The vehicle on platform no.4 can now be driven off the platform.

Numbering

Standard numbering of the parking spaces:

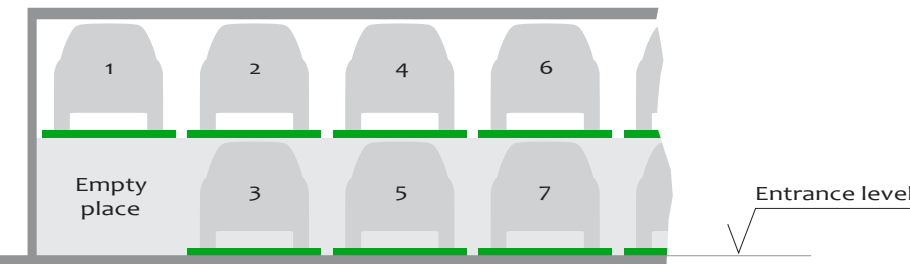

Initial position: upper floor platform No. 1 at entrance level (covering of pit, safety regulation).

Different numbering is only possible at extra cost.

Please take note of the following specifications:

- In general, the empty space must be arranged to the left.
- The numbers must be provided 8 – 10 weeks before the delivery date.

Page 1
Sections, dimensions, car data

Page 2
Variants and Height dimensions

Page 3
Width dimensions without garage doors

Page 4
Width dimensions pillars position

Page 5
Width dimensions pillars position

Page 6
Width dimensions roll door

Page 7
Rails width dimensions tolerances

Page 8
Access incline Load plan

Page 9
Installation function numbering

Page 10
Electrical installation

Page 11
Technical hint

Page 12
To be performed by the customer

Page 13
Technical description

Electrical installation

Switch cabinet and master switch



Access to the switch cabinet (about 100 x 60 x 40 cm) must be possible without danger.
The lockable master switch must be positioned so that the entire entry area of the facility can be surveyed.
With wall opening from switch cabinet to system (consultation with manufacturer required).

Hydraulic unit

- 3 kW, 3 phase 400 V/50 Hz/8 A
- Alternative versions for a surcharge:
- 5,2 kW, 3 phase 400 V/50 Hz/13.8 A

Supply cable to master switch

Standard sliding doors with one hydraulic unit:

Customer-provided supply cable min. 5 x 2.5 mm² (3 PH+N+PE) to master switch with pre-fuse 3 x 16 A (slow T) or circuit breaker 3 x 16 A (trip characteristic K).

National and local laws and regulations regarding electrical energy supply must be observed.

The customer must lay the supply cable to the master switch during assembly. Functional capability can be checked by our engineers on site, in conjunction with the electronics engineer. If this is not possible during assembly for reasons attributable to the customer, the customer must commission an electronics engineer.

The customer must earth the steel structure with a foundation earth connection (earthing distance max. 10 m) and equipotential bonding in accordance with DIN EN 60204.

Control panel with emergency-stop

- Attachment at a clear point (e.g. pillar)
- Secured against external operation

The control unit must be accessible from the outside at all times! Approximate dimensions 30 x 30 x 30 cm.

Wall cut from the control unit to the parking system (contact the manufacturer for clarification).

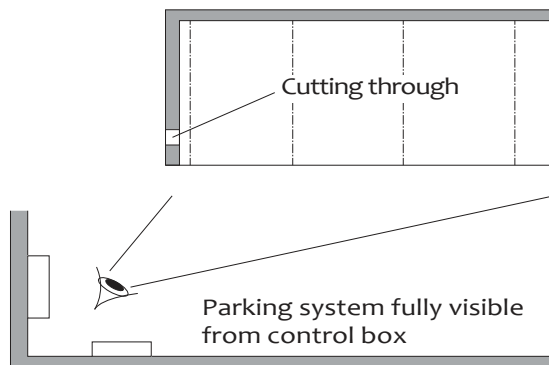

Page 1
Sections,
dimensions,
car data

Page 2
Variants
and Height
dimensions

Page 3
Width
dimensions
without
garage doors

Page 4
Width
dimensions
pillars
position

Page 5
Width
dimensions
pillars
position

Page 6
Width
dimensions
roll door

Page 7
Rails
width
dimensions
tolerances

Page 8
Access incline
Load plan

Page 9
Installation
function
numbering

Page 10
Electrical
installation

Page 11
Technical
hint

Page 12
To be
performed by
the customer

Page 13
Technical
description

Technical hint**Application area**

By default, the system is not suitable for short-term parkers (changing users). If necessary, please contact producer of parking system.

Power pack

Installed on vibration metal mounted, low-noise hydraulic power units. Nevertheless, we recommend separating the garage from the house.

Available documents

- Wall recess plans
- Maintenance offer/contract
- Declaration of conformity

Corrosion protection

According to the supplementary sheet of corrosion protection.

Balustrade / Barriers

When the allowable fall is exceeded, balustrades are attached to the equipment. If the traffic lanes are directly next to or behind the installations, barriers according to DIN EN 294 (DIN EN ISO 13857) are required on site. This also applies during the construction phase.

Environmental conditions

Ambient conditions for the range of our parking systems: Temperature range -10 to +40° C. Relative humidity 50% with a maximum outside temperature of +40° C. If lifting or lowering durations are mentioned, these refer to an ambient temperature of +10° C and an arrangement of the system immediately next to the hydraulic unit. At lower temperatures or longer hydraulic lines, these durations increase.

Soundproofing

According to DIN 4109 (sound insulation in building construction), para. 4, note 4, parking systems fall into the field of technical installations (garage systems).

Normal sound insulation (Special agreement) DIN 4109, Supplement 4, Note for planning and execution, proposals for increased sound insulation. In paragraph 4.1, Table 4, the values for the permissible sound pressure levels in rooms requiring protection are specified for noise from building services. According to line 2, the maximum sound pressure level in living rooms and bedrooms must not exceed 30 dB (A). Noise from the user is not subject to the requirements (see Table 4, DIN 4109).

The following measures are required to maintain this value:

- Soundproofing package according to offer/order
- Sound insulation of the building in min. $R'w = 57$ dB (performance on site)

Increased sound insulation

DIN 4109, paragraph 4, noise protection of technical equipment and installations.

Agreement: Maximum sound pressure level in living rooms and bedrooms 25 dB (A). User noises are not subject to the requirements (see Table 4, DIN 4109).

The following measures are required to maintain this value:

- Soundproofing package according to offer/order
- Sound insulation of the building in min. $R'w = 62$ dB (performance on site)



HINT: The user's noises are essentially noises that can be individually influenced by the user of our parking systems. These include for example driving on the platform, slamming vehicle doors, engine noise and brake.

Page 1
Sections,
dimensions,
car data

Page 2
Variants
and Height
dimensions

Page 3
Width
dimensions
without
garage doors

Page 4
Width
dimensions
pillars
position

Page 5
Width
dimensions
pillars
position

Page 6
Width
dimensions
roll door

Page 7
Rails
width
dimensions
tolerances

Page 8
Access incline
Load plan

Page 9
Installation
function
numbering

Page 10
Electrical
installation

Page 11
Technical
hint

Page 12
To be
performed by
the customer

Page 13
Technical
description

To be performed by the customer**Balustrade / Barriers**

Possibly required barriers according to DIN 294 for securing the parking pits in traffic lanes directly in front of, beside or behind the facilities. This also applies during the construction phase. Railings on the systems, if required, are included optional!

Numbering of parking spaces

Continuous numbering of parking spaces.

Building services

Lighting, ventilation, fire extinguishing and fire alarm systems.

Lighting

The customer must observe local regulations pertaining to the illumination of parking spaces and roadways. In accordance with DIN EN 12464-1 'Light and lighting - Lighting of work places', an illumination level of min. 200 lx is recommended for the parking spaces and operating area of the system.

Drainage

For the middle area of the pit, we recommend a drainage channel, which you connect to a floor drain system or sump (50 x 50 x 20 cm). The drainage channel may be inclined to the side, however not the pit floor itself (longitudinal incline is available). In the interest of environmental protection, we recommend painting the pit floor, and to provide oil and petrol separators in the connections to the public sewage system.

Wall cutout

There is a possibility of requiring openings in the walls according to the section on page 1.

Strip footings

If due to structural conditions strip footings must be effected, the customer shall provide an accessible platform reaching to the top of the said strip footings to enable and facilitate the mounting work.

Electrical supply to the control box/Foundation earth connector

The supply line to the main switch and the control line to the unit must be made by the customer during installation. The functionality can be checked by our technicians on site together with the electrician. If this is not possible during assembly for reasons attributable to the customer, an electrician must be commissioned by the customer. The steel construction is to be provided on site with foundation earthing connection (grounding distance max 10 m) and potential equalization according to DIN EN 60204.

Door suspensions

Lintel height „H1“ (see “Width dimensions”, pages 3,4 and 5) is absolutely necessary. With differing heights, additional fixings are required at extra cost.

The following costs are borne by the investor, unless otherwise defined in the offer:

- Complete wiring of individual components according to the attached diagram
- Costs of technical testing/certification, if required by local laws
- Main switch
- Power supply line to the main cabinet
- Floor marking

Other services on-site

- Preparation of the parking system pit
- Measures for the implementation of water protection regulations
- Measures to comply with fire protection regulations and noise protection in accordance with DIN4109
- Pit measurement
- Daily update on project photos, if required
- Foundation grounding if necessary
- All permits and approvals

Page 1

Sections, dimensions, car data

Page 2

Variants and Height dimensions

Page 3

Width dimensions without garage doors

Page 4

Width dimensions pillars position

Page 5

Width dimensions pillars position

Page 6

Width dimensions roll door

Page 7

Rails width dimensions tolerances

Page 8

Access incline Load plan

Page 9

Installation function numbering

Page 10

Electrical installation

Page 11

Technical hint

Page 12

To be performed by the customer

Page 13

Technical description

Technical description of the semi-automatic parking system

General description

- Parking systems provides independent parking spaces for cars, one on top of the other and sideways.
- Dimensions are in accordance with the underlying dimensions of height and width.
- The parking bays are accessed horizontally. Platforms have a gradient of $\pm 1^\circ$ for proper drainage.
- An access traffic lane (in accordance with local regulations) must be available along the entire width of the system.
- The platforms of the upper floor (UF) are moved vertically, the platform on the ground floor (GF) horizontally. At approach level (GF) there is always one parking space less available. This vacant space is used for shifting the ground floor (GF) parking spaces sideways, thus enabling the upper platform (UF) parking space located above to be lowered to approach/ground level. Consequently, a unit of three parking spaces (1 on the ground floor, 2 on the upper floor) is the smallest unit available for this parking system.
- For safety reasons, the platforms can only be moved behind electromagnetically locked doors.
- All necessary safety devices are installed. This consists mainly of a chain monitoring system, locking lever for the upper and lower platforms and electromagnetic door locks. The doors can only be opened if the selected parking space has reached the park position and all openings are secured.
- Operating instructions at every operating point.

The steel frame of the parking system consists of:

- Serial supports
- Steel pillars with sliding platform support
- Cross and longitudinal members
- running rails for the transversely movable ground floor (GF) platform
- Dowels, screws, fasteners, connecting elements etc.

Lifting device for upper floor (UF) platforms consist of:

- Hydraulic cylinder with solenoid valve
- Chain wheel
- Chain
- Limit switches
- The platforms are suspended on four points and guided along the supports using plastic sliding bearings

Hydraulic unit consist of:

- Hydraulic power unit (low-noise, installed onto a console with a metal mounting)
- Hydraulic oil reservoir
- Oil filling
- Internal geared wheel pump
- 3 phase AC motor (3 kW, 400VAC, 50 Hz)
- Pressure relief valve
- Hydraulic hoses
- Manometer (optional)
- Safety valve

Drive unit of transversely movable platforms on the ground floor (GF)

- Gear motor with chain wheel
- Chains
- Running and guide rollers (low-noise)
- Power supply via cable

Control system:

- Central operator panel (operating device) used to select the desired parking space
- Electric wiring is made from the electric cabinet by the manufacturer
- Main cabinet

Platform consist of:

- Driving paths (transverse treads)
- Side members
- Cross members
- Platform base sections
- 1 wheel-stop (on the left per parking space)
- screws, small parts, etc.

Laterally movable doors:

Size

Sliding door, dimensions: approx. 2500 mm x 2000 mm (width x height).

Frame

Frame construction with vertical centre stay bar made from steel pipe.

Standard door panel

Wire mesh: Mesh size 50x50x3,8

Running rails

The running gear of each door consists of 2 twin-pair rolling gadgets, adjustable in height.

The running rails of the doors are fixed to brackets or the concrete lintel, or on a building-specific door suspension using ceiling fittings.

The guide consist of 2 plastic rollers mounted to a base late, witch is doweled to the floor.

Door drive

Electric drive via electric motor mounted to the rail system at the turning point of the sliding doors.

The drive pinion engages into the chain mounted to the door.

For safety reasons, the movement of the platforms is always made behind locked doors. Position sensing, i.e. "door open" and "door closed" is affected by electric signals.



Note: Door panels (on the side, cover for running rails, etc.) and door suspensions are not included in the standard version but can be delivered against surcharge as special equipment.

Page 1

Sections, dimensions, car data

Page 2

Variants and Height dimensions

Page 3

Width dimensions without garage doors

Page 4

Width dimensions pillars position

Page 5

Width dimensions pillars position

Page 6

Width dimensions roll door

Page 7

Rails width dimensions tolerances

Page 8

Access incline Load plan

Page 9

Installation function numbering

Page 10

Electrical installation

Page 11

Technical hint

Page 12

To be performed by the customer

Page 13

Technical description

We reserve the right to change these specifications without prior notice

Manufacturer reserves the right in the course of the technical progress to use newer or other technologies, system, processes, procedures or standards in the fulfillment of their obligations other than those originally offered.